

Composite Conducting Polymer Coatings on Mild Steel Electrode and Corrosion Protection

F. YILDIRIM

Department of Chemistry and Chemical Processing Technologies, Pamukkale University, Denizli, Turkey

Corresponding author: Fax: +90 258 2118065; Tel: +90 258 2123788; E-mail: fati@pau.edu.tr

Received: 28 December 2018;

Accepted: 13 March 2019;

Published online: 21 May 2019;

AJC-19409

Multilayered polypyrrole/polyaniline (PPy/PANI) and PANI/PPy coatings were deposited by 30 successive scan between -600 and 1500 mV on mild steel electrode. Electrochemical impedance spectroscopy was used to clarify the ability of these composites to provide an effective barrier to corrosion in 0.1 M NaCl solution. For long exposure time, the performance of composite coatings on steel was not sufficiently better than for single PANI or for single PPy coating. EIS measurements show that the degree of protection is a function of the deposition order of composites and ion exchange properties of these films.

Keywords: Conducting polymers, Polypyrrole, Polyaniline, Composites, Corrosion.

INTRODUCTION

Electroactive conducting polymers have been the subject of electrochemical research for many years. There has been recently interest on the possible use of them as either film forming corrosion inhibitors or protective coating. PANI and PPy act as good corrosion inhibitors for metals [1-16]. Among them some composed systems and bilayers are of special interest [6,17-19]. Conducting polymers are known as rectifying or charge trapping devices. Charge trapping phenomena in conducting polymers significantly increase their conductivity. High electronic and ionic resistances of the inner film in the reduced state are advantageous in minimizing charge leakage [20]. The trapping of charge in the inner or outer layer was qualitatively characterized for many bilayer systems [20].

There are a few studies for the formation of adherent PANI/PPy composite coatings on steel using oxalic acid as electrolyte [18,19]. The electrochemical deposition parameters such as applied potential and the feed ratio of comonomers influenced the nature of formed composite coatings [21]. Aqueous electro-deposition process of conducting polymers is widely preferred because its simplicity in construction. PPy and PANI also form an adherent film on mild steel in aqueous oxalic acid solution.

In the present study, adherent PANI, PPy, PANI/PPy and PPy/PANI bilayer coatings were obtained on mild steel in oxalic acid solution by successive cyclic voltametric technique.

Protection ability of these polymers against corrosion is explained by trapping of charge in the inner or outer layers of composites.

EXPERIMENTAL

Carbon steel rods (1 cm in diameter) were embedded in cylindrical Teflon rods that only bottom surface were exposed to solution. The surface of the electrode were then polished with different grades of emery paper down to 1200 grit and washed with bidistilled water.

The electrochemical and corrosion experiments were carried in a traditional three-electrode cell. The counter electrode was a platinum plate and the reference electrode was saturated calomel electrode. PANI film was deposited from 0.1 M aniline and 0.3 M oxalic acid solution by cyclic voltametric method scanning between -600 mV and $+1500$ mV with a scan rate of 20 mV/s with 30 cycles. PPy film was prepared from 0.1 M pyrrole and 0.1 M oxalic acid with the same procedure at the same potential range and potential scan rate. Two different types of conducting polymer coatings deposited with the above-mentioned procedure. PANI film was first deposited and then PPy or *vice versa*. Corrosion experiments were performed at room temperature with 0.1 M NaCl solution.

A Volta Lab 40 (PGZ 301 Dynamic-EIS Voltametry) potentiostat was used in all voltametric studies. The polymer coated electrodes were washed with bidistilled water and then

the corrosion behaviour of mild steel covered by the electro-deposited polymer films was investigated by the AC impedance technique. The AC impedance measurements were also carried out at open circuit potentials with a Volta Lab 40 potentiostat. The superimposed sinusoidal voltage signal of 10 mV amplitude was applied. The impedance measurements were carried out in the frequency region of 50 mHz to 20 kHz, taking five points per decade. The real (Z') and imaginary (Z'') components of the impedance spectra in the complex plane were analyzed using the Circular Regression programmer in the Volta Lab 40 potentiostat. Soýf XJP-6A model metal microscope was used to investigate the changes on polymer covered surfaces after corrosion experiments.

Electrochemical impedance spectroscopy (EIS) is used widely to study kinetic properties of thin films of electroactive polymers, corrosion and inhibition of metals. All the electrochemical measurement techniques depend on the theoretical model to explain the experimental results. It is assumed that the conducting polymers formed on mild steel has thin channels and swelling structure. In addition, it was assumed that when conducting polymers covered electrode dipped into the electrolyte solution, film channels immediately filled with electrolyte. In present study, model film has two interfaces, one is between metal and polymer, second is between polymer and electrolyte phase. Each interface has its own capacitance and resistance values. Equivalent circuit considered for the corrosion of PANI or PPy coated mild steel in 0.1 M NaCl solutions is shown in Fig. 1. At low frequency region impedance Z_{film} is taken as equal to the sum of polymer film resistance and the solution resistance.

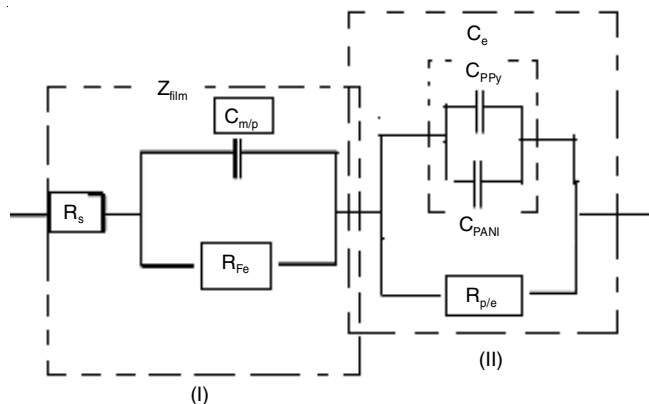

Fig. 1. Equivalent circuit considered for the corrosion of PANI or PPy or PPy/PANI or PANI/PPy coated mild steel in 0.1 M NaCl solution. For composite coatings, C_e represents equivalent capacitance of composites

Impedance data were analyzed by the equivalent circuit given in Fig. 1. R_s is the electrolyte resistance, C_{mp} is taken as the equivalence to the capacitance of metal/polymer interface, R_{Fe} is taken equivalent to the anodic metal dissolution resistance in the metal/polymer interface, $R_{p/e}$ and C_{PPy} or C_{PANI} are taken as the polymer/electrolyte ion exchange resistance and capacitance, respectively. C_e represents equivalent capacitance of composites. R_s , C_{mp} , R_{Fe} , $R_{p/e}$ and C_e (or $C_{PPy/PANI}$ and $C_{PANI/PPy}$) values are found from the circular regression analysis of first and second semicircle according to model Nyquist graph in Fig. 2.

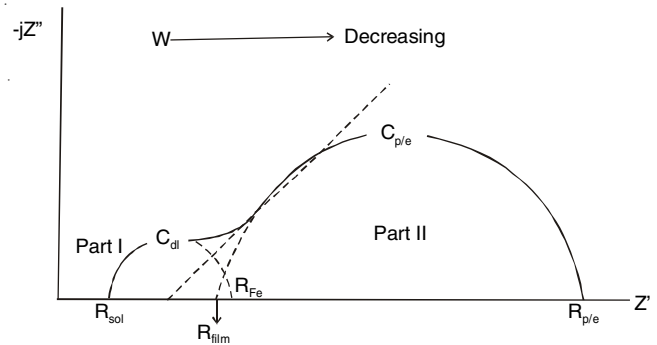

Fig. 2. Model Nyquist plot used to find R_s , C_{mp} , R_{Fe} , $C_{p/e}$, R_{mp} values

RESULTS AND DISCUSSION

Anodic and cathodic polarization curves for the four types of coated mild steel and for bare steel electrode in 0.1 M NaCl for short and long exposure time are displayed in Figs. 3-7. The corrosion potentials, corrosion current densities and corrosion rates abstracted from these curves are shown in Table-1. However all the coatings cause positive shift in corrosion potential and expected to decrease in corrosion rate, compared to bare mild steel electrode, except PANI/PPy coating caused to increase corrosion rates in short exposure times. For long exposure times corrosion potentials of covered electrodes shift to negative values with time but their values are about 200 mV higher than the corrosion potential of bare steel electrode and corrosion current densities take very small values. The absence of passivity with coatings for a short immersion times were surprising since passive layer of Fe(II)oxalate has previously been reported to form on carbon steels when coating PANI or PPy from oxalic acid [22]. The absence of passivity with the negative shifts in the corrosion potential suggest that PPy/PANI or PANI/PPy accelerated the corrosion of the carbon steel by bimetallic corrosion [19].

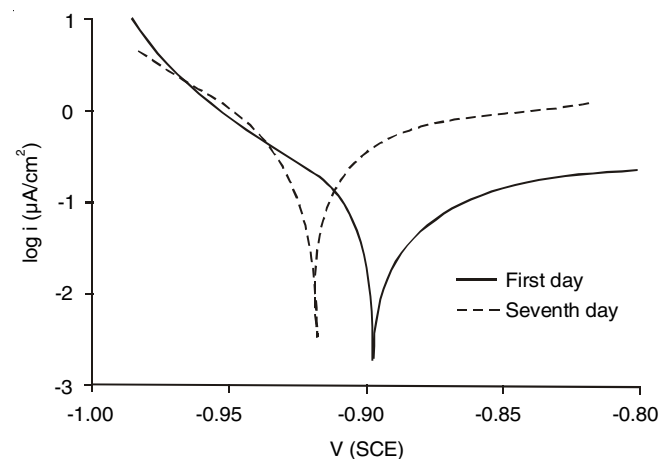

Fig. 3. Tafel plots for bare steel in 0.1 M NaCl solution

Electrochemical impedance measurements at open circuit potential give more information about this discrepancy. Nyquist plots for the corrosion of conducting polymers covered steel electrodes in 0.1 M NaCl solution, measured after various exposure times at corrosion potential are shown in Figs. 8-12.

TABLE-1
KINETIC PARAMETER OBTAINED FROM CURRENT-POTENTIAL CURVES

Time	Substance	E_{corr}	I_{corr} ($\mu\text{A}/\text{cm}^2$)	β_a (mV)	β_c (mV)	Rate (mm/year)
Immediately after exposure	Bare	-911.2	26.5	–	-38.2	30.5
	PANI	-370	53.7	104.3	-76.9	928.1
	PPy	-152.3	27.2	95.3	-81.3	318
	PANI/PPy	-684.1	3.2	45.4	-128.3	37.1
	PPy/PANI	-379.6	91	93.1	-90.8	100.1
After one week exposure	Bare	-955.3	301.8	144.1	–	309.6
	PANI	-693.9	3.3	51.5	-46.9	38.2
	PPy	-663.1	2.2	39.2	-133.3	25.8
	PANI/PPy	-717.4	1.9	78.1	-15.2	0.021
	PPy/PANI	-709.5	2.1	43.9	-23.3	12.7

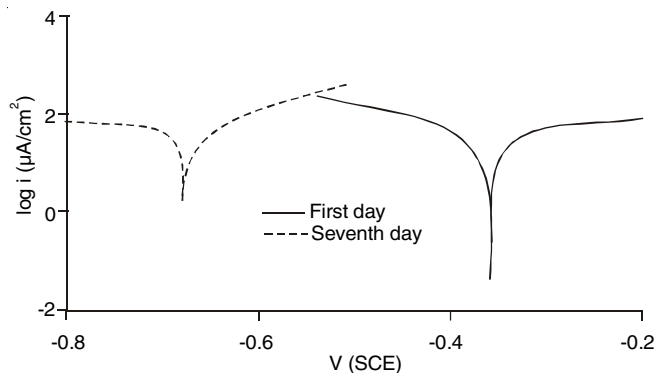

Fig. 4. Tafel plots for PANI coated mild steel in 0.1 M NaCl solution

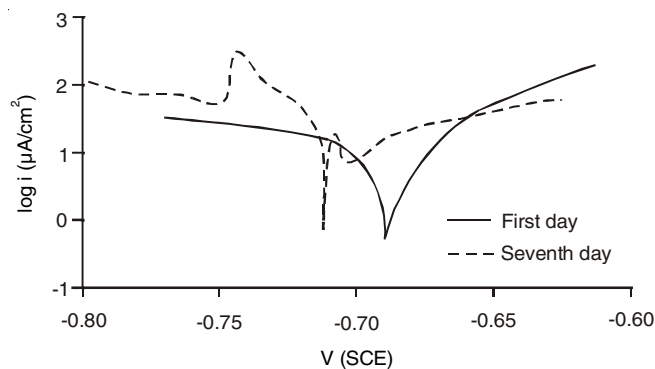

Fig. 6. Tafel plots for PANI/PPy coated mild steel in 0.1 M NaCl solution

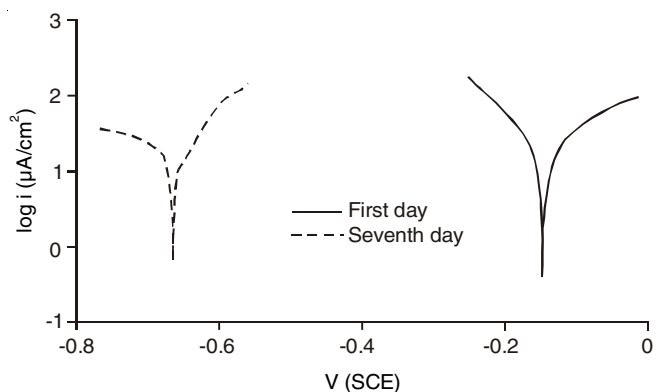

Fig. 5. Tafel plots for PPy coated mild steel in 0.1 M NaCl solution

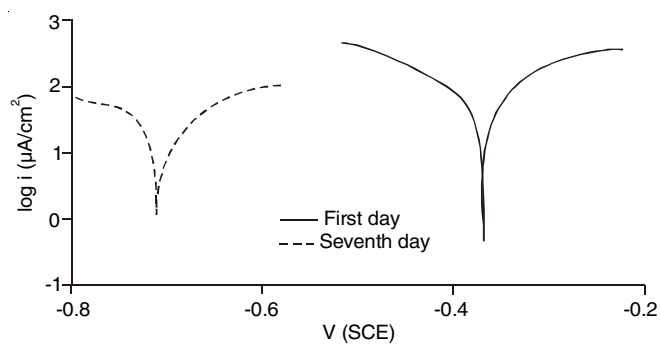

Fig. 7. Tafel plots for PPy/PANI coated mild steel in 0.1 M NaCl solution

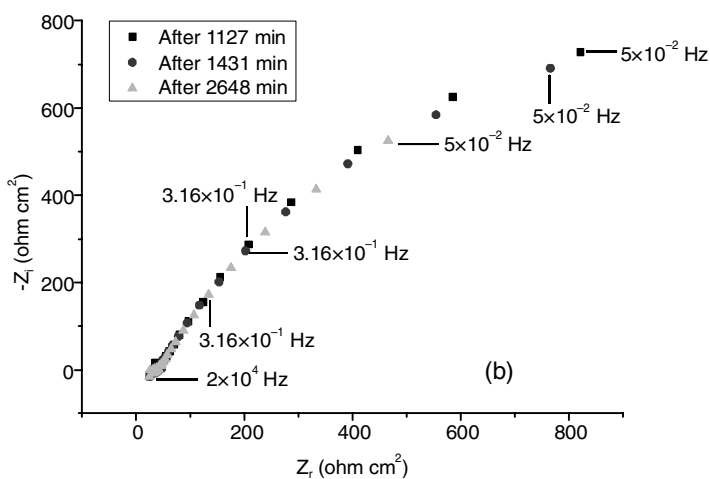
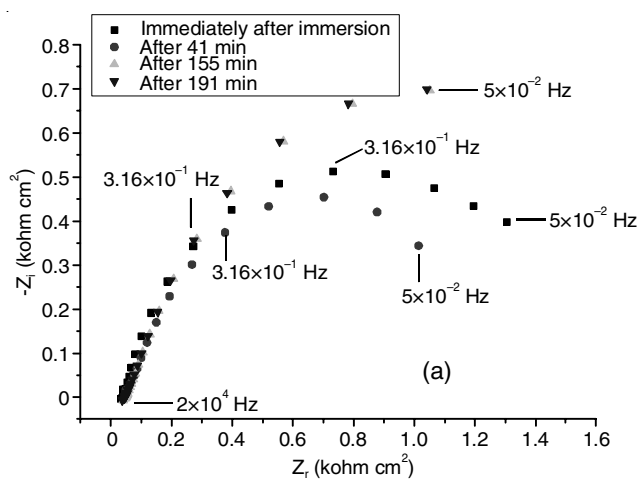

Fig. 8. (a-b) Nyquist plots for the corrosion of bare steel in 0.1 M NaCl solution measured after various exposure times

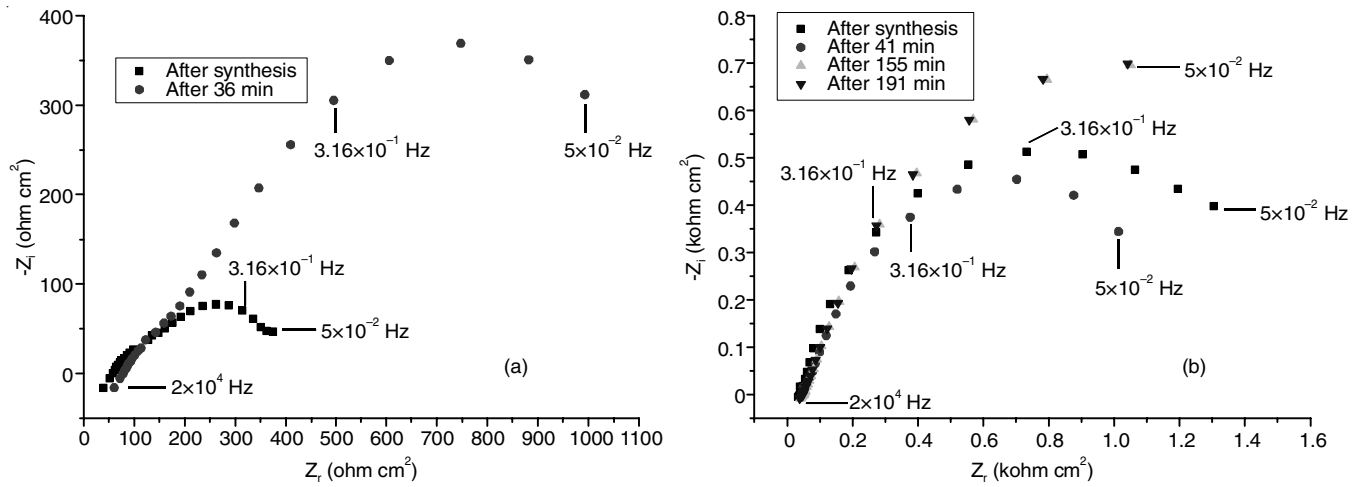

Fig. 9. (a-b) Nyquist plots for the corrosion of PANI covered mild steel in 0.1 M NaCl solution measured after various exposure times

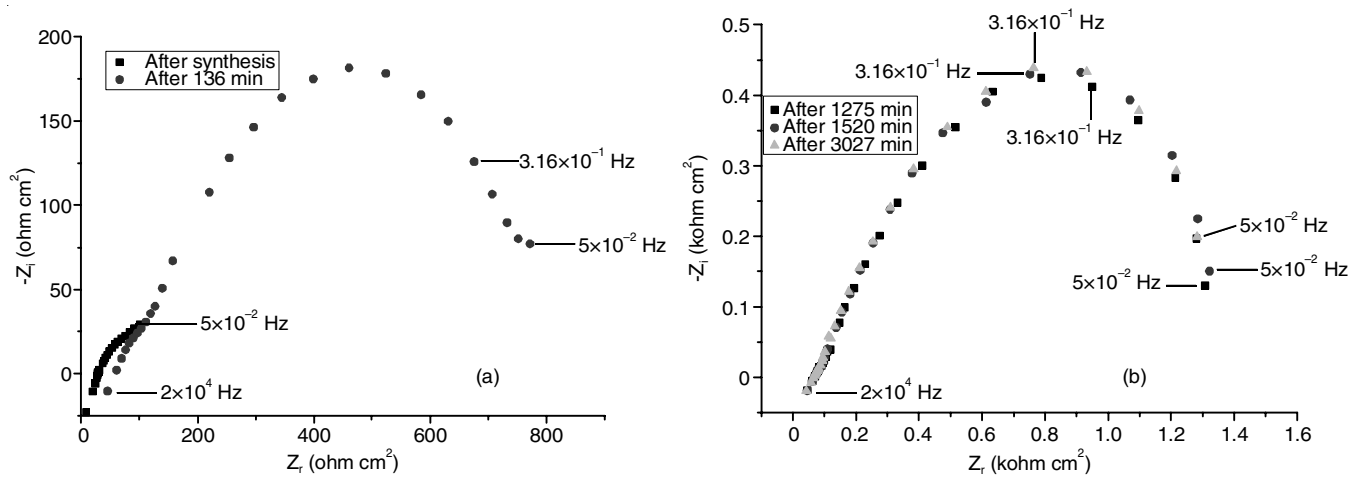

Fig. 10. (a-b) Nyquist plots for the corrosion of PPy covered mild steel in 0.1 M NaCl solution measured after various exposure times

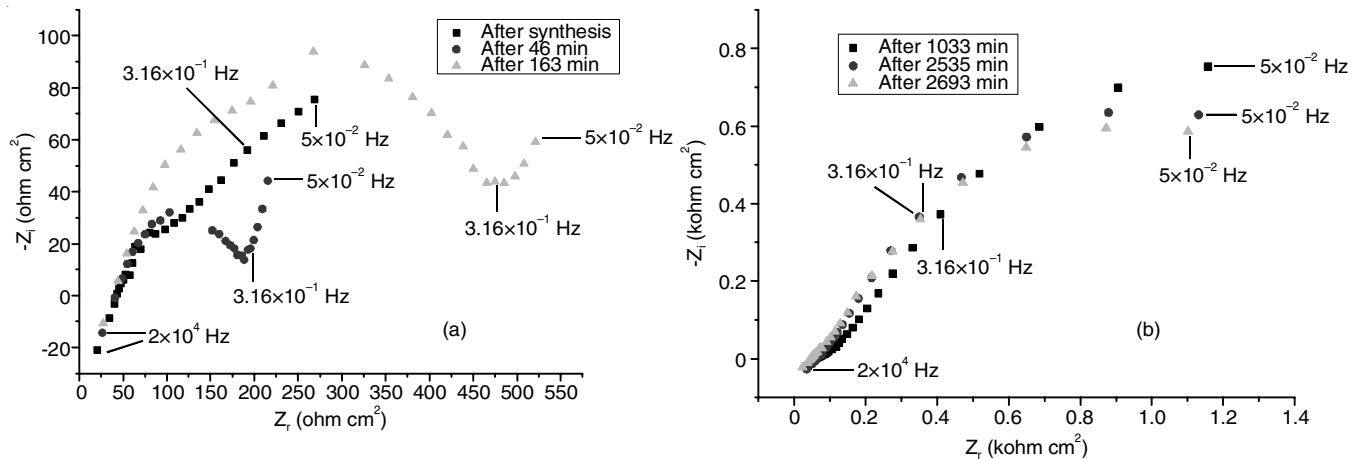

Fig. 11. (a-b) Nyquist plots for the corrosion of PANI/PPy covered mild steel in 0.1 M NaCl solution measured after various exposure times

For conducting polymers covered electrodes, Nyquist plots show the two capacitive loops, a smaller one at high frequency range (part I) followed by a larger one at lower frequencies (part II) in 0.1 M NaCl solution (Figs. 8a and 12a). For long exposure times one semicircle was obtained (Figs. 8b and 12b). Impedance data were analyzed by the equivalent circuit given in Fig. 1. The circular regression analyzes of the Nyquist plots

in Figs. 8-12 were performed according to Fig. 1 and the EIS parameters are shown in Table-2.

At high frequency region for the analysis of Nyquist plots, equivalent circuit of part (I) in Fig. 1 was attributed to the dissolution as Fe^{2+} after the channels filled with water uptake. For this reason $C_{m/p}$ and R_{Fe} values were found from the first loop, since the process has shorter time constant, $\tau = RC$ and

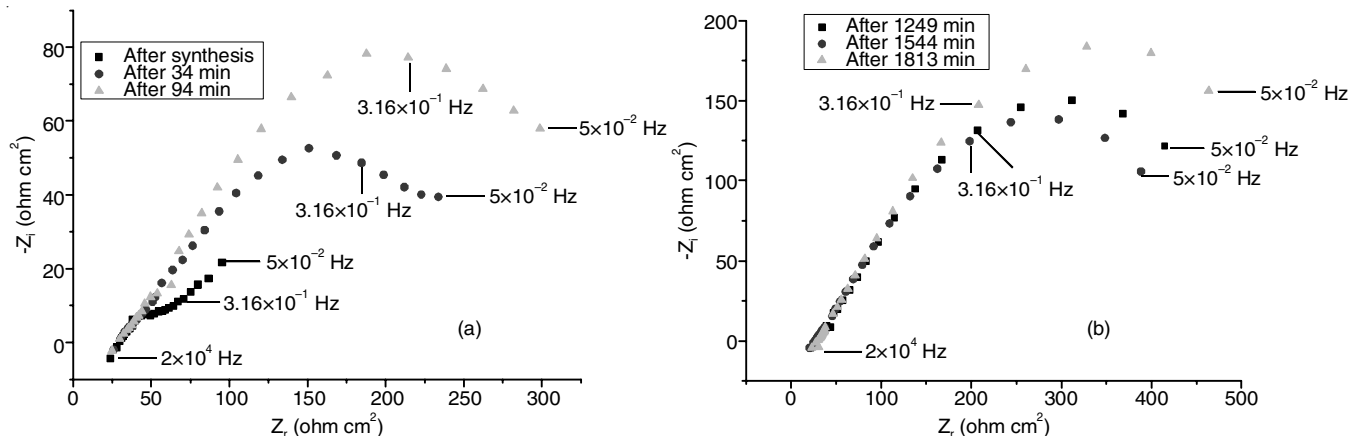

Fig. 12. (a-b) Nyquist plots for the corrosion of PPy/PANI covered mild steel in 0.1 M NaCl solution measured after various exposure times

TABLE-2
RESISTANCE AND CAPACITANCE VALUES OBTAINED FROM NYQUIST PLOTS

Exposure time	Surface	R_s (ohm cm^2)	$R_{m/p}$ (ohm cm^2)	R_{film} (ohm cm^2)	$R_{p/e}$ (ohm cm^2)	$C_{m/p}$ ($\mu F/cm^2$)	$C_{p/e}$ ($\mu F/cm^2$)
Immediately after exposure	Bare	37.79	1550	—	—	324.3	—
	PANI	55.85	163.4	90	334.8	12.26	598.9
	PPy	27.70	90.08	—	—	3533	—
	PANI/PPy	42.33	160.1	—	—	198.7	—
	PPy/PANI	29.35	55.42	—	—	907.4	—
After 1172 min	Bare	38.72	2379	—	—	1337	—
	PANI	—	—	69.35	1660	—	302.8
	PPy	68.26	449.2	133.7	1172	1.119	271.4
	PANI/PPy	58.78	129.2	98.36	2107	9.852	1510
	PPy/PANI	27.28	30.73	41.97	523.7	103.5	2431
After 2815 min	Bare	37.69	2444	—	—	1302	—
	PANI	—	—	124.4	1969	—	404.1
	PPy	63.12	169.8	110.4	1240	4.684	405.4
	PANI/PPy	—	—	81.20	1823	—	1746
After 1655 min	PPy/PANI	25.05	37.78	38.96	470.6	53.06	2705
After 1813 min	PPy/PANI	—	—	38.20	492.8	—	2583

diminishes with time. R_{Fe} is taken as the polarization resistance of the corrosion reaction takes place at the metal/polymer interface. When the outer surface of cover of conducting polymer in contact with the electrolyte, water uptake and ion exchange process begin at the same time. The variation in exposure times of R_s , $C_{m/p}$ and R_{Fe} values were shown in Figs. 13-15 and Table-2.

Corrosion process at the metal/conducting polymer interface can be explained as:

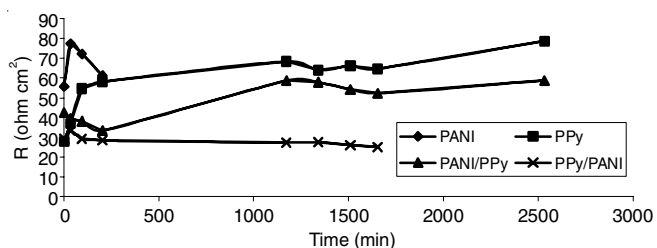
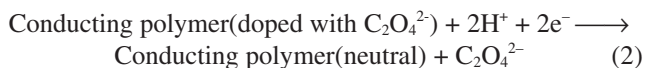
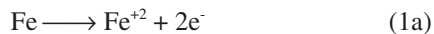

Fig. 13. R_s , resistance of the solution during the immersion times of coated steel in 0.1 M NaCl solution

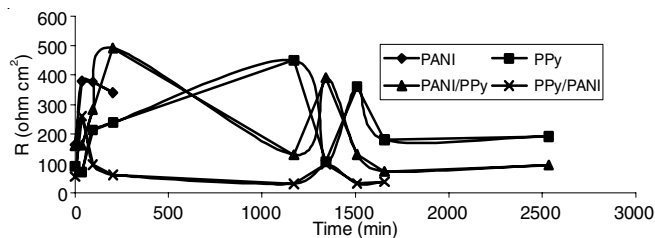

Fig. 14. R_{Fe} , corrosion resistance of mild steel between metal/polymer interface in 0.1 M NaCl solution during immersion times

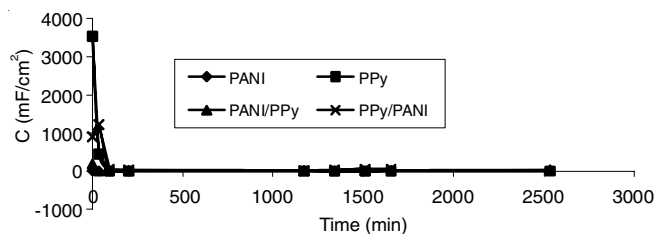
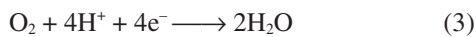

Fig. 15. $C_{m/p}$, capacitance of metal/polymer interface in 0.1 M NaCl solution during immersion times

According to this, analysis corrosion rate is high at the metal/conducting polymer interface, but does not proceed further since cathodic reaction in this region is the reduction of conducting form to non-conducting form reduced form accom-

panied by the concurrent ion dedoping processes. Oxalate ions in PPy or in PANI act as double charged poorly moving dopants. In short exposure time reaction (2) stops, since oxalate ions are exhausted at the metal/conducting polymer interface. Corrosion of conducting polymers covered mild steel in 0.1 M NaCl solution depends on ion exchange properties of these films. Moreover precipitation of Fe(II)oxalate and hydroxide filled the ends of channels and hinders further dissolution.

The second rate controlling reaction occurs at polymer/electrolyte interface at the same time with the metal/polymer interface. One can expect that the outer surface of conducting polymers in contact with electrolyte react with dissolved oxygen. Ion exchange especially with chloride ions helps to oxidation of polymer surface. In prolonged exposure time reduction of oxygen and oxidation of conducting polymers with ion exchange reaction are the main processes at CP/electrolyte interface.



CP(doped with oxalate) + Chloride ions \rightarrow Oxidized form (doped with chloride ions) + protons + electrons (4)

R_{film} , $C_{\text{p/e}}$ and $R_{\text{p/e}}$ values were obtained from the circular regression analysis of Nyquist plots in Figs. 8-12 and shown in Figs. 16-18.

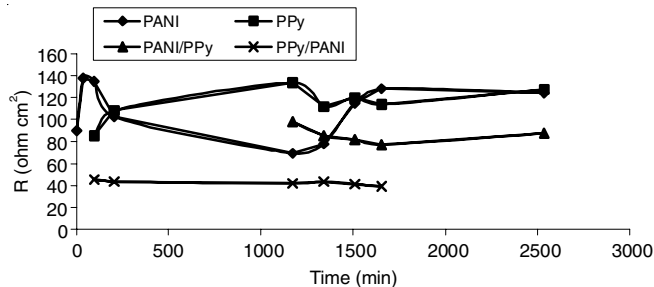

Fig. 16. R_{film} for coated steel during immersion in 0.1 M NaCl solution

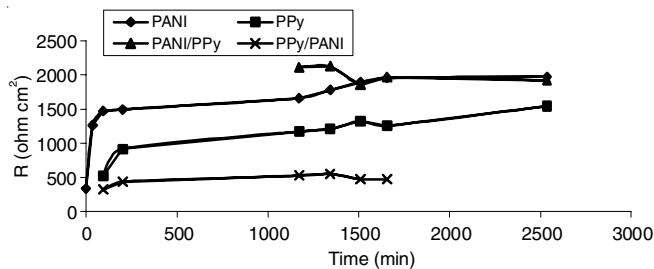

Fig. 17. $R_{\text{p/e}}$ for coated steel during immersion in 0.1 M NaCl solution

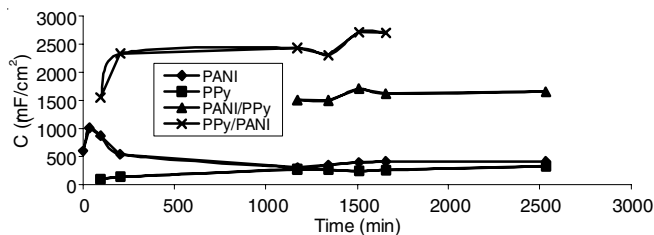

Fig. 18. $C_{\text{p/e}}$ for coated steel during immersion in 0.1 M NaCl solution

According to these explanations two sides of the coatings charged differently. Slow charge transfer kinetics on the polymer/electrolyte interface makes these systems as charge

trapping system. After one week immersion time in 0.1 M NaCl solution conducting polymers coverings show good barrier protection and their adhesion to the metal was good except PPy/PANI covering (Fig. 19). After the experiment, it is scraped hardly from the surface.

According to Figs. 13 and 16 wetted film resistance and solution resistance are close to each other. This means that polarization resistance of corrosion reaction between metal/conducting polymer interface is unimportant compared with the polarization resistance of ion exchange reaction (Fig. 17).

It is observed that the correlation between i_{corr} values obtained from Tafel plots and $R_{\text{m/p}}$ values obtained from the circular regression analysis of first loop in Figs. 8-12 immediately after electrode dipped into the solution. For short immersion times i_{corr} values are high and then $R_{\text{m/p}}$ values are low. $R_{\text{m/p}}$ values change between 100 and maximum 500 ohm/cm². If these values are used as polarization resistance of steel and the Tafel slopes from Table-1, calculated i_{corr} values from Stern-Geary equation are changed between

$$i_{\text{corr}} = \frac{\beta_a \beta_c}{2.303(\beta_a + \beta_c)R_p}$$

38 $\mu\text{A}/\text{cm}^2$ and 190 $\mu\text{A}/\text{cm}^2$. These values are between the i_{corr} values obtained from Tafel plots for short immersion times and i_{corr} values of bare steel electrode after long immersion times.

For long immersion times i_{corr} values are low and then $R_{\text{m/p}}$ values are high. As a conclusion for short immersion time conducting polymers increases iron corrosion, but for long immersion times ion exchange process determines the corrosion rate. According to Table-1, underlying polymer film determines the corrosion rate for short immersion times. Immediately after exposure, $R_{\text{m/p}}$ values for PANI and PANI/PPy are 163.4 and 160.1 ohm/cm², respectively and 90 and 55 ohm/cm² for PPy and PPy/PANI in the experimental error, respectively.

Fig. 19 shows the surface photographs of the PANI, PPy, PANI/PPy and PPy/PANI covered electrodes after 1 week exposure to 0.1 M NaCl solutions. For long exposure times, ion exchange polarization resistances of these films are 1969, 1240, 1823 and 492 ohm/cm², respectively. These results are in accordance with the appearance of the surface photographs of the film. The covering, which has the highest ion exchange polarization resistance, does protect electrode against to corrosion. PPy/PANI film, which has the lowest ion exchange polarization resistance, does not protect metal surface from corrosion.

Conclusion

According to Table-1, PANI/PPy coating protects mild steel against corrosion better than PANI or PPy coatings. The same results can be drawn if ion polarization resistances are taken as the corrosion resistances of conducting polymers films (Table-2). PANI/PPy coating has the highest ion polarization resistance and PPy/PANI film has the lower ion polarization resistance than the components. After 2800 min, ion exchange resistance of PANI/PPy coating reaches to ion exchange resistance of PANI. However PANI/PPy film resistance stays constant at about 490 ohm/cm². According to these results PANI/PPy or PPy/PANI system has bilayer structure at the beginning.

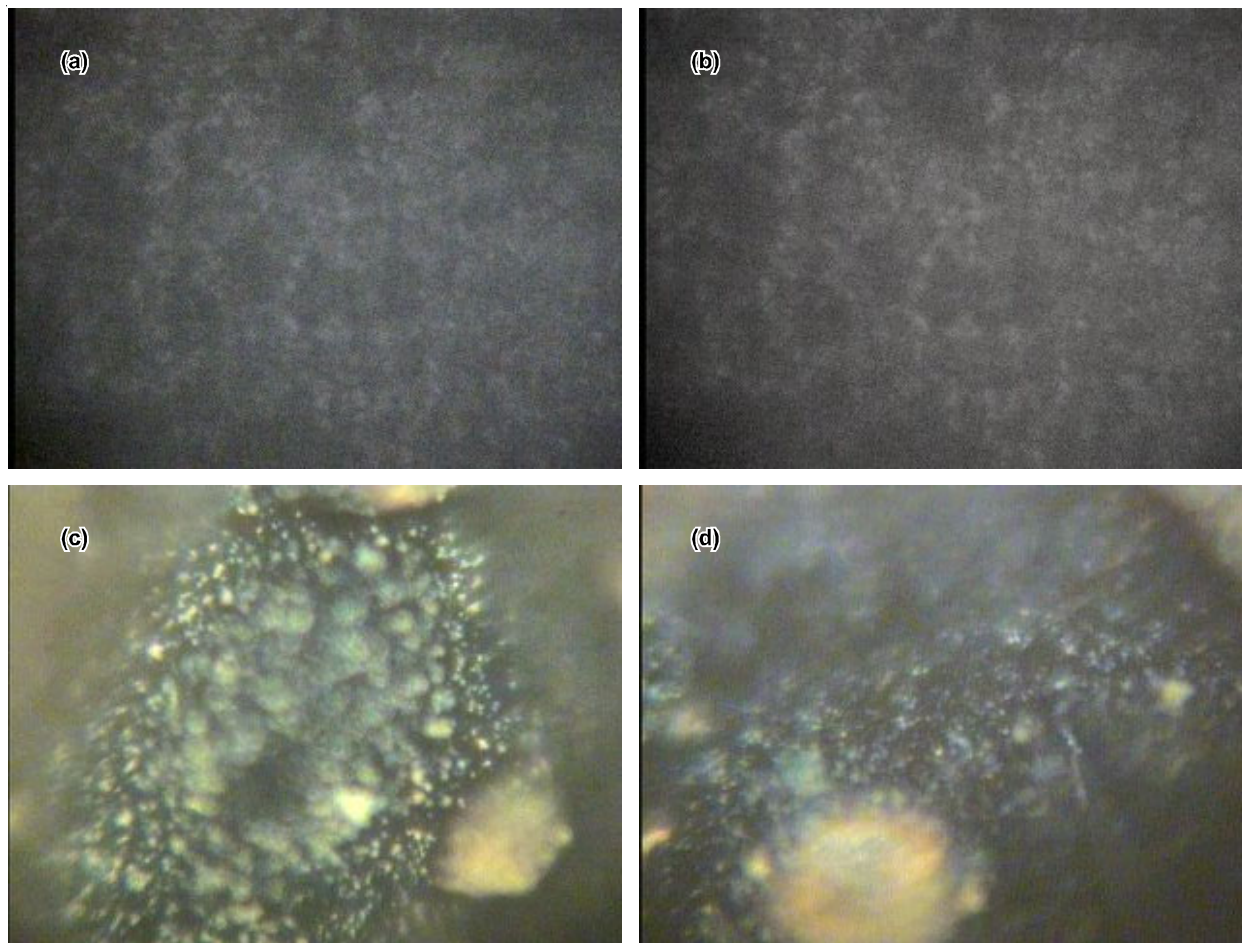

Fig. 19. Optic microscopic films after immersion 0.1 M NaCl solution (1 week immersed) for (a), (b) PANI/PPy, (c), (d) PPy/PANI

For long immersion time there may be an arrangement in the structure accompanying with ion exchange reaction. PPy/PANI structure is more favourable to ion exchange than PANI/PPy, PPy and PANI coatings.

CONFLICT OF INTEREST

The authors declare that there is no conflict of interests regarding the publication of this article.

REFERENCES

- J. Petitjean, S. Aeiyaich, J.C. Lacroix and P.C. Lacaze, *J. Electroanal. Chem.*, **478**, 92 (1999); [https://doi.org/10.1016/S0022-0728\(99\)00418-0](https://doi.org/10.1016/S0022-0728(99)00418-0).
- C.A. Ferreira, S. Aeiyaich, J.J. Aaron and P.C. Lacaze, *Electrochim. Acta*, **41**, 1801 (1996); [https://doi.org/10.1016/0013-4686\(95\)00498-X](https://doi.org/10.1016/0013-4686(95)00498-X).
- K.G. Conroy and C.B. Breslin, *Electrochim. Acta*, **48**, 721 (2003); [https://doi.org/10.1016/S0013-4686\(02\)00741-7](https://doi.org/10.1016/S0013-4686(02)00741-7).
- D.W. DeBerry, *J. Electrochem. Soc.*, **132**, 1022 (1985); <https://doi.org/10.1149/1.2114008>.
- S. Jasty and A.J. Epstein, *Polym. Mater. Sci. Eng.*, **72**, 565 (1995).
- Y. Wei, J. Wang, X. Jia, J.M. Yeh and P. Spellane, *Polymer*, **36**, 4535 (1995); [https://doi.org/10.1016/0032-3861\(95\)96866-7](https://doi.org/10.1016/0032-3861(95)96866-7).
- N. Ahmad and A.G. MacDiarmid, *Synth. Met.*, **78**, 103 (1996); [https://doi.org/10.1016/0379-6779\(96\)80109-3](https://doi.org/10.1016/0379-6779(96)80109-3).
- J.R. Santos Jr., L.H.C. Mattoso and A.J. Motheo, *Electrochim. Acta*, **43**, 309 (1998); [https://doi.org/10.1016/S0013-4686\(97\)00052-2](https://doi.org/10.1016/S0013-4686(97)00052-2).
- P.J. Kinlen, D.C. Silverman and C.R. Jeffreys, *Synth. Met.*, **85**, 1327 (1997); [https://doi.org/10.1016/S0379-6779\(97\)80257-3](https://doi.org/10.1016/S0379-6779(97)80257-3).
- P.C. Seanson and T.P. Moffat, *Crit. Rev. Surf. Chem.*, **3**, 171 (1994).
- G. Troch-Nagels, R. Winand, A. Weymeersch and L. Renard, *J. Appl. Electrochem.*, **22**, 756 (1992); <https://doi.org/10.1007/BF01027506>.
- T.P. McAndrew, *Trends Polym. Sci. (Regul. Ed.)*, **5**, 7 (1997).
- S. Sathiyarayanan, S.K. Dhawan, D.C. Trivedi and K. Balakrishnan, *Corros. Sci.*, **33**, 1831 (1992); [https://doi.org/10.1016/0013-4686\(92\)90187-8](https://doi.org/10.1016/0013-4686(92)90187-8).
- Y. Wei, J.-M. Yeh, H. Wang, X. Jia, C. Yang and D. Jin, *Polym. Mater. Sci. Eng.*, **4**, 202 (1996).
- S. Sathiyarayanan, K. Balakrishnan, S.K. Dhawan and D.C. Trivedi, *Electrochim. Acta*, **39**, 831 (1994); [https://doi.org/10.1016/0013-4686\(94\)80032-4](https://doi.org/10.1016/0013-4686(94)80032-4).
- I. Sekine, K. Kohara, T. Sugiyama and M. Yuasa, *J. Electrochem. Soc.*, **139**, 3090 (1992); <https://doi.org/10.1149/1.2069037>.
- R. Racicot, R.L. Clarck, H.-B. Liu, C. Yang, M.N. Alias and R. Brown, *SPIE-Int. Soc. Opt. Eng.*, **2528**, 251 (1995).
- R. Rajagopalan and J.O. Iroh, *Electrochim. Acta*, **46**, 2443 (2001); [https://doi.org/10.1016/S0013-4686\(01\)00357-7](https://doi.org/10.1016/S0013-4686(01)00357-7).
- C.K. Tan and D.J. Blackwood, *Corros. Sci.*, **45**, 545 (2003); [https://doi.org/10.1016/S0010-938X\(02\)00144-0](https://doi.org/10.1016/S0010-938X(02)00144-0).
- A.R. Hillman and E.F. Mallen, *J. Electroanal. Chem.*, **281**, 109 (1990); [https://doi.org/10.1016/0022-0728\(90\)87033-G](https://doi.org/10.1016/0022-0728(90)87033-G).
- J.O. Iroh and R. Rajagopalan, *Surf. Eng.*, **16**, 321 (2000); <https://doi.org/10.1179/026708400101517314>.
- J.L. Camalet, J.C. Lacroix, S. Aeiyaich, K. Chane-Ching and P.C. Lacaze, *J. Electroanal. Chem.*, **416**, 179 (1996); [https://doi.org/10.1016/S0022-0728\(96\)01012-1](https://doi.org/10.1016/S0022-0728(96)01012-1).