

ORIGINAL ARTICLE

The Mediating Role of Well-Being in the Relationship Between Personality Traits and Internet Addiction

Aykut Günlü¹, Aslı Uz Baş²¹Department of Child Care and Youth Services, Pamukkale University, Denizli, Turkey²Department of Educational Sciences, Dokuz Eylül University Faculty of Education, İzmir, Turkey

ORCID IDs of the authors: A.G. 0000-0002-6617-2871, A.U.B. 0000-0001-8307-6198.

Main Points

- It is seen that there is a negative relationship between openness to experience and internet addiction.
- There was a negative correlation between extroversion personality trait and internet addiction.
- A negative correlation was found between compatibility and internet addiction.
- A negative relationship was found between emotional stability and internet addiction.
- Personality traits lead to a decrease in the level of well-being of the individual; the decrease in the level of well-being causes an increase in the level of internet addiction of the individual.

Abstract

The aim of this study is to examine the mediating effect of well-being in the relationship between personality traits and internet addiction. This descriptive study was conducted using a quantitative research approach and the relational survey model. The sample of the research consisted of 452 students. PERMA Scale, Young's Internet Addiction Test Short Form, and Quick Big Five Personality Scale were used in the study. In this study, a negative relationship was observed between the personality traits of agreeableness, conscientiousness, emotional stability, openness to experience, and internet addiction, but no relationship was observed between extraversion and internet addiction. The results show that well-being plays a full mediator role in the relationship between personality traits and internet addiction. Researchers can prepare psychoeducational programs to reduce internet addiction and plan experimental/semi-experimental studies to determine the effectiveness of these programs.

Keywords: Big five theory, internet addiction, personality traits, positive psychology, well-being

Introduction

Today, the access to and use of the internet have become quite widespread among the individuals of all ages. The fact that the internet facilitates human life also diversifies and differentiates the purpose of its use for individuals (Kuss et al., 2013). In a study conducted by the Turkish Statistical Institute (TUIK), it was determined that the first three purposes of internet use are as follows: messaging, making phone calls over the internet, and creating a profile on social media and sharing photos (Turkish Statistical Institute [TUIK], 2019).

The internet has some disadvantages as well as the abovementioned advantages (Davis, 2001). The observation that the internet has some harm has led researchers to conduct studies on revealing the causes of these harms. Some of these studies focused on the time spent on the internet and reported that the duration of internet use was quite high among university youth and this situation negatively affected their academic achievement (Kaya, 2019). Another area where the negative effects of the internet are seen is the physical and mental health (Kaya et al., 2016; Uz Baş et al., 2016). Due to the disadvantages of the internet, internet addiction is

Corresponding Author:
Aykut Günlü
E-mail: agunlu@pau.edu.tr

Received: October 5, 2021
Accepted: November 23, 2021

©Copyright by 2022 Türkiye Yeşilay Cemiyeti (Turkish Green Crescent Society) - Available online at www.addicta.com.tr

Cite this article as: Günlü, A., & Uz Baş, A. (2022). The mediating role of well-being in the relationship between personality traits and internet addiction. *Addicta: The Turkish Journal on Addictions*, 9(1), 31-37.

seen as an important problem (Bozkurt, et al., 2016; Yang & Kim, 2018). Internet addiction is one of the operational addictions and has similar characteristics to the symptoms seen in substance addiction.

One of the factors affecting internet addiction is personality traits (Cole & Hooley, 2013). Personality is an important factor influencing an individual's behavior. Personality is the set of characteristics that distinguish an individual from others, are predicted to be shown against different events, and have continuity (Burger, 2006; Costa & McCrea, 1992). It is important to determine the personality traits of individuals in the addiction cycle. Because virtual environments offer the opportunity to keep one's identity and personality hidden, they can cause individuals to communicate without revealing their personality and identity. For this reason, it would be appropriate to give a detailed explanation about the big five personality theory, which is one of the antecedent theories dealing with personality. The personality theory was developed by Costa and McCrea (1992) based on the trait approach. While the dimension "extraversion" emphasizes the communicative and social aspect of the individual, the dimension "conscientiousness" emphasizes the ability to fulfill one's duties. The dimension "agreeableness" emphasizes the individual's ability to be with other people, to communicate smoothly, and to work together. While the dimension "openness to experience" refers to being open to development and change and being able to adapt easily, "neuroticism" refers to emotional stability (Burger, 2006).

Previous studies reported different results about the relationship between addiction and personality traits. Some studies asserted that introversion and internet addiction are positively related (Engelberg & Sjöberg, 2004; Tuten & Bosnjak, 2001). In another study, internet addiction was found to be closely related to the dimension neuroticism, that is, emotional instability (Servidio, 2014). On the other hand, Dong et al. (2013) reported that narcissistic personality traits and internet addiction were associated with deprivation, difficulty in control, and social isolation, and the internet addicts were found to have high emotional inconsistency (stability) scores. However, in a study conducted by Servidio (2014), it was asserted that there was no relationship between internet addiction and emotional inconsistency. It was observed that the personality trait "neuroticism" was the strongest predictor of internet addiction, while "agreeableness" was the second strongest. On the other hand, Kuss et al. (2013) reported that the dimension "neuroticism" predicted internet addiction, and emotional inconsistency increased the level of internet addiction.

Well-being is a concept that has come to the fore in the literature with positive psychology. Well-being refers to being happy and having the ability to approach problems positively (Karababa et al., 2018). There are many different definitions in the literature for addressing the concept of well-being. As a result, different well-being approaches have emerged in the literature. One of these models is Martin Seligman's Multidimensional Model of Well-Being (Demirci et al., 2017). According to Seligman, well-being consists of different dimensions that form a new whole. According to him, well-being should be defined with the following five dimensions: positive emotions, engagement, positive relationships, meaning, and accomplishment (Seligman,

2002). Thanks to the fact that these dimensions can be measured both independently and as a whole (Lovett & Lovett, 2016), this model is widely used. Well-being is classified as follows: subjective well-being and psychological well-being. While subjective evaluations of the individual are at the forefront in subjective well-being, the evaluations of mental health specialists are taken into account in psychological well-being (Dost, 2005). In the literature, well-being is also classified as hedonic well-being and eudaimonic well-being. The former focuses on the dimensions of happiness, positive affect, and life satisfaction, and the latter on the dimensions of the meaning and purpose of life (Uz Baş, 2018).

Studies in the literature have reported that well-being is related to personality traits (Anglim & Grant, 2016; Doğan, 2013). They reported that the personality traits "extraversion," "emotional instability," and "conscientiousness" were positively related to subjective well-being. In the study conducted by Cenkseven & Akbaş, 2007, it was asserted that the personality traits "neuroticism" and "extraversion" were significant predictors of subjective well-being. In another study, it was reported that the use of the internet was effective in the individuals' subjective well-being, life satisfaction, and self-esteem, and experience of negative emotions (Durak & Durak, 2011). In a study conducted by Derin and Bilge (2016), it was reported that individuals with high scores in life satisfaction and positive emotions, which are sub-dimensions of well-being, had low scores in the internet addiction scale. Therefore, it can be asserted that having a high level of well-being is effective in overcoming negative life events in a short time (Asıcı, 2019).

The researches on negative results of the internet use show that it has a significantly negative effect on the well-being of individuals. However, previous studies reported contradicting results about the relationship between personality traits and internet use; so, there is still a need for more research on internet addiction. Therefore, in the present study, it was aimed to examine the mediating effect of well-being in the relationship between personality traits and internet addiction.

Methods

Model of the Research

This descriptive study was conducted using a quantitative research approach and the relational survey model.

Participants

The sample consisted of 452 students who continued their education at university in the 2019 – 2020 academic year and accepted to participate in the study voluntarily. They were selected by convenience sampling method from the departments of child development and psychological counseling and guidance. Data on demographic characteristics of the sample are presented in Table 1.

As seen in Table 1, of 452 students, 399 (88%) were females and 53 (12%) were males; 389 participants (86.1%) were from Pamukkale University and 63 (13.9%) from Dokuz Eylül University; 187 (41.4%) of the participants were studying at the department of psychological counseling and guidance, and 265 (58.6%) at the department of child development. It was observed that the group was between the ages of 18 and 22 years.

Table 1.
Demographic Characteristics of the Sample Group

Variables	n	%
Gender		
Female	399	88
Male	53	12
University		
Dokuz Eylül University	63	13.9
Pamukkale University	389	86.1
Chapter of faculty		
Psychological counseling and guidance	187	41.4
Child development	265	58.6
Age		
18	60	12.8
19	102	22.9
20	134	29.6
21	96	21.2
22	59	13.1
Total	452	100

Data Collection Tools

Personal Information Form

It consisted of questions aimed at collecting information about the participants' gender, university, department, age, duration of internet use, and purpose of internet use.

Young's Internet Addiction Test Short Form

The Internet Addiction Test developed by Young was adapted into a short form by Pawlikowski et al. (2013). The Turkish adaptation study of the scale was carried out by Kutlu et al. (2016). It is a 12-item one-dimensional scale with no reverse-scored items. It was reported that the scale met the validity conditions. In addition, the reliability of the scale was reported to be at an acceptable level (.91). The higher the scale score, the higher the level of internet addiction.

PERMA Scale

It was developed by Butler and Kern (2015) and adapted into Turkish by Demirci et al. (2017). PERMA well-being model is based on measuring well-being in five dimensions (positive emotions, engagement, positive relationships, meaning, and achievements). It is a 23-item scale, and 8 of the scale items are filler items, and 15 of them are included in the scoring. Demirci et al. (2017) reported the reliability of the scale as 0.91, and its validity as 0.73 – 0.86. PERMA scale yields a score for each sub-dimension and an overall well-being score.

Quick Big Five Personality Test

The scale was developed by Vermulst and Gerris (2005) and adapted by Morsünbül (2014). It measures five personality traits known as "Big Five" (extraversion, agreeableness, conscientiousness, emotional stability, and openness to experience) using 30 adjectives (6 adjectives for each trait). This 7-point Likert scale yields a score between 6 and 42, and it is based on the reverse

coding of 12 of 30 items. It was reported that the reliability of the scale was 0.81 for extraversion, 0.80 for agreeableness, 0.86 for conscientiousness, 0.78 for emotional stability, and 0.78 for openness to experience.

Process

The data of the study were collected from the students who participated in the study voluntarily. A link with an online form was sent to the participants, and it was specifically stated that it would be beneficial to fill it out whenever they felt the most ready. Pearson product – moment correlation coefficient and structural equation model were used to analyze the data. Statistical Package for the Social Sciences (SPSS), version 16 (SPSS Inc., Chicago, IL, USA), and Analysis of Moment Structures (AMOS) 20 software packages were used in this analysis.

Analysis of Data

First of all, descriptive statistics of the variables were discussed and the relations between them were examined. Afterward, structural equation modeling (SEM) was carried out (Meydan & Şeşen, 2015). The parcel application includes the sum/average of the scores for more than two items, provided that there are at least two items, and these scores are used in the SEM (Bandalos, 2002). Thus, the reliability and validity of latent variables can be increased and usable scores can be obtained (Little et al., 2013). In the light of this information, internet addiction includes three sub-dimensions. The dimensions of conscientiousness, openness to experience, and agreeableness were included in the model, while the dimensions of extraversion and emotional stability were not included. The correlation values for the new dimensions are given in Table 3.

Results

In this section, first of all, the relations between the variables were analyzed and then the structural equation model was tested for the mediating role of well-being. The correlation values between the variables, the skewness and kurtosis coefficients, the standard deviation, and the mean values are given in Table 2.

As seen in Table 2, it was determined that the variables were normally distributed. When the correlation coefficients were examined, it was found that well-being was positively correlated with agreeableness ($r = .59, p < .01$), conscientiousness ($r = .51, p < .01$), emotional stability ($r = .29, p < .01$), and openness to experience ($r = .44, p < .01$). Moreover, a negative correlation was found to exist between well-being and internet addiction ($r = -.41, p < .01$) and between internet addiction and agreeableness ($r = -.22, p < .01$), extraversion ($r = -.09, p < .01$), conscientiousness ($r = -.33, p < .01$), emotional stability ($r = -.28, p < .01$), and openness to experience ($r = -.13, p < .01$).

As seen in the analysis results in Table 3, the observed variables were significantly related to each other. Before performing the SEM analysis, the measurement model between the observed variables and the latent variables obtained by the parcellation method was tested. Values related to the measurement model are given in Figure 1. As a result of the procedures, it was seen that the measurement model was confirmed and the fit indices were at an acceptable level ($\chi^2/SD = 4.97, p < .000$, Root Mean Square

Table 2.
Correlation Values Between Latent Variables of the Study

Variables	1	2	3	4	5	6	7
1. Perma	–						
2. Internet Addiction	–.41**	–					
3. Compatibility	.59**	–.22**	–				
4. Extraversion	.27**	–.09	.20**	–			
5. Responsibility	.51**	–.33**	.48**	.03	–		
6. Emotional stability	.29**	–.28**	.19**	.44**	.13**	–	
7. Openness to experience	.44**	–.13**	.55**	.13**	.28**	.06	–
\bar{X}	6.9.	26.21	34.59	35.44	30.12	25.39	30.78
S.S.	1.43	7.75	5.16	7.94	7.41	7.06	5.78
Skewness	–.58	.47	–.61	–.06	–.52	.04	–.17
Kurtosis	.24	–.04	.41	–.59	–.19	–.63	–.49

** $p < .01$.

Error of Approximation (RMSEA) = .09, Standardised Root Mean Square Residual (SRMR) = .09, Goodness-of-Fit Statistic (GFI) = .93, Comparative fit index (CFI) = .95). In addition, the fact that the factor loads varied between .61 and .87 also shows that the observed variables represented the latent variables significantly.

Structural Equation Model Regarding the Mediation Role of Well-Being in the Relationship Between Personality Traits and Internet Addiction

In order to test the mediator variable model in the structural equation model, there must be a significant relationship between dependent/independent and mediator variables (Baron & Kenny, 1986). However, when we look at Table 2, there is no significant relationship between some variables; so, the variables were analyzed with the newly created sub-dimensions. In the parceling method, it was seen that the fit indices were at an acceptable

level. Structural equation modeling requires first constructing and verifying the measurement model and then testing the structural model (Meydan & Şeşen, 2015). In the structural equation model, it was determined that the results were at an acceptable level ($\chi^2/SD = 4.97$, $p < .01$, RMSEA = .09, SRMR = .51, GFI = .93, the Adjusted Goodness-of-Fit Statistic (AGFI) = .88, Normed-fit index (NFI) = .94, Tucker Lewis index (TLI) = .93, CFI = .95). The resulting model is presented in Figure 2.

According to the analysis, it was determined that personality traits predicted well-being positively ($\beta = .28$, $p < .01$), and well-being predicted internet addiction negatively ($\beta = -.80$, $p < .01$). When the tool variable well-being was added to the model, it was observed that the predictive power of the personality traits for internet addiction ($\beta = .03$, $p < .01$) decreased. In other words, the personality traits significantly predicted ($\beta = .03$, $p < .01$) internet addiction through well-being.

Table 3.
Correlation Values Between Observed Variables of the Study

Variables	1	2	3	4	5	6	7	8	9	10	11
1. pp_3	–										
2. pe_3	.72**	–									
3. pr_3	.72**	.61**	–								
4. pm_3	.74**	.71**	.66**	–							
5. pa_3	.63**	.74**	.56**	.77**	–						
6. Compatibility	.48**	.57**	.47**	.50**	.53**	–					
7. Responsibility	.39**	.52**	.33**	.47**	.54**	.48**	–				
8. Openness to experience	.32**	.43**	.31**	.43**	.43**	.55**	.28**	–			
9. YIB parcel 1	–.27**	–.33**	–.26**	–.39**	–.45**	–.16**	–.34**	–.12*	–		
10. YIB parcel 2	–.26**	–.28**	–.21**	–.32**	–.34**	–.18**	–.29**	–.10*	.66**	–	
11. YIB parcel 3	–.29**	–.29**	–.30**	–.30**	–.35**	–.25**	–.25**	–.12*	.62**	.69**	–

* $p < .05$; ** $p < .01$.

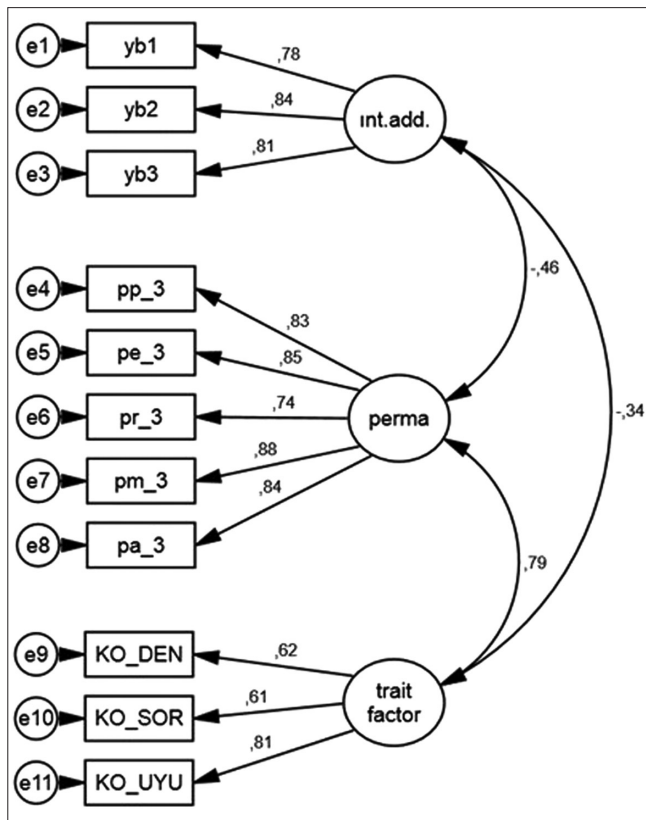

Figure 1. Analysis Results Regarding the Measurement Model.

Bootstrapping Process

The statistical significance of the direct and indirect effects in the obtained SEM, in other words, the exact mediating role of the mediator variable was tested by bootstrapping. Bootstrapping is an analysis process that allows testing the mediating role of a variable in structural equation model (Preacher & Hayes, 2008).

Table 4. Bootstrap Analysis Results Examining the Statistical Significance of the Direct and Indirect Effects of the Structural Equation Model

Model Paths	Coefficient	95% CI	
		Lower	Upper
Direct effect			
Trait factor → PERMA	.79**	.70	.86
Trait factor → internet addiction	-.34**	-.46	-.22
PERMA → internet addiction	-.51**	-.75	-.30
Indirect effect			
Trait factor → PERMA → internet addiction	-.40**	-.61	-.25

*p < .05; **p < .01.

The coefficients obtained as a result of the bootstrapping analysis and the CIs for the coefficients are presented in Table 4.

Based on the results in Table 4 and the values obtained as a result of the bootstrapping process, the direct path coefficients were found to be significant. However, it is seen that indirect path relationships were also significant ($\beta = -.40$, 95% CI = $-.61$ to $-.21$). According to these results, it can be asserted that well-being plays a full mediator role in the relationship between personality traits and internet addiction.

Discussion and Limitations and Directions/ Suggestions for Future Research

In the present study, the mediating role of well-being in the relationship between personality traits and internet addiction was examined in a sample of university students. The results show

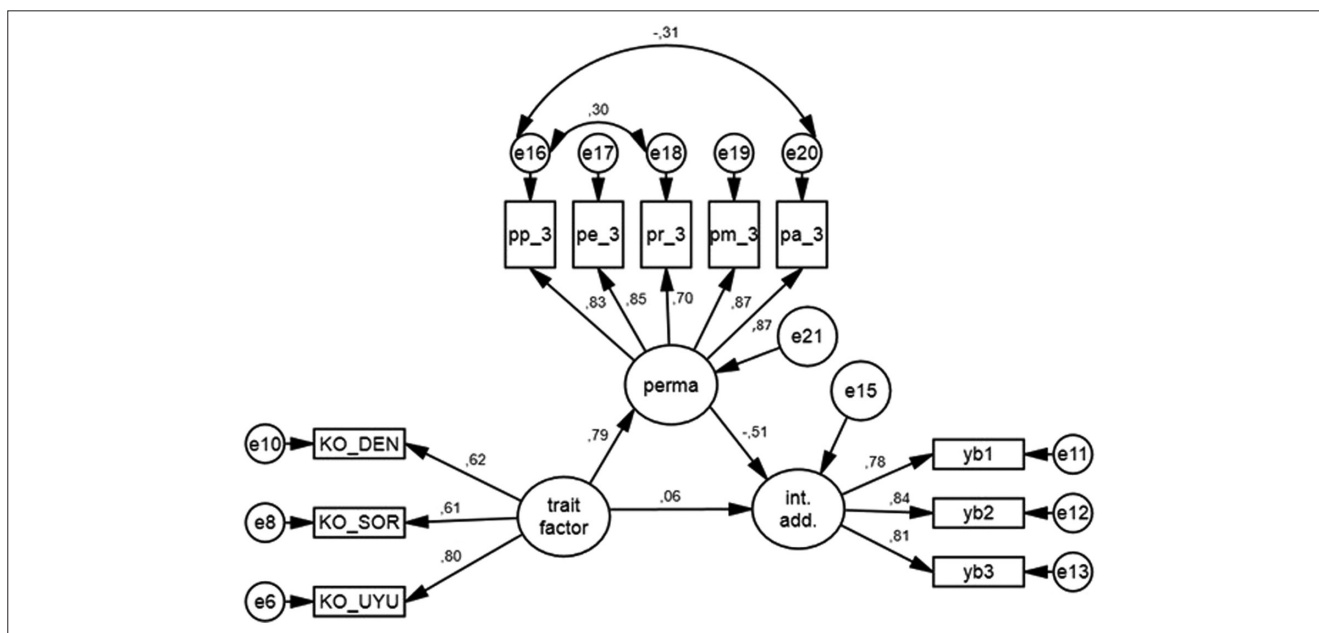

Figure 2. Testing the Mediator Role of Well-Being in the Relationship Between Personality Traits and Internet Addiction.

that well-being plays a full mediator role in the relationship between personality traits and internet addiction. In other words, the personality traits lead to a decrease in the level of well-being, and the decrease in the level of well-being causes an increase in the level of internet addiction.

In this study, a negative relationship was observed between internet addiction and the personality traits of agreeableness, conscientiousness, emotional stability, and openness to experience, while no relationship was observed between extraversion and internet addiction. Previous studies reported contradicting results in this regard. While some studies reported a positive relationship between internet addiction and the personality trait “extraversion” (Ekşi, 2012, Hardie & Yi-Tee, 2007; Landers & Lounsbury, 2006; Servidio, 2014), some others reported a negative relationship (Chen, 2013; Çelik et al., 2012). As for the present study, it was found that there was no relationship between extraversion and internet addiction. However, a negative relationship was found to exist between openness to experience and internet addiction. Some previous studies reported a negative relationship between openness to experience and internet addiction (Ekşi, 2012, Gündüz et al., 2017; Landers & Lounsbury, 2006; Servidio, 2014), but some others reported a positive relationship (Çelik et al., 2012). There are studies reporting a positive relationship between introversion, another sub-dimension of personality traits, and internet addiction (Durak Batıgün & Kılıç, 2011, Engelberg & Sjöberg, 2004; Koch & Pratarelli, 2004).

In the present study, a negative relationship was found to exist between agreeableness and internet addiction. While some previous studies reported a negative relationship between agreeableness and internet addiction (Gündüz et al., 2017), some others reported a positive relationship (Çelik et al., 2012). In the literature, there are studies reporting a positive relationship between neuroticism and internet addiction (Gündüz et al., 2017; Serin, 2011), but there are also studies reporting a negative relationship (Çelik et al., 2012). In the present study, a negative relationship was found to exist between emotional stability and internet addiction. Serin (2011) reported that there was a negative relationship between emotional stability and internet addiction. On the other hand, Servidio (2014) asserted that there was no relationship between emotional stability and internet addiction.

As a result, it was seen that the personality traits affected internet addiction through well-being. Considering that the mediator variable had a full mediating role, it can be asserted that increasing well-being can be effective in decreasing the level of internet addiction.

This study has some limitations. First, the data of the study were collected from a sample of students from two departments of two universities. Second, the research data were limited to the information obtained from the scales.

According to the results of the current study, the following suggestions can be made for future studies. Psychological counselors providing psychological support services can prepare psychoeducational programs to increase the well-being of individuals and carry out individual and group works. Psychological counseling, guidance, and application centers of universities can organize

training programs in order to increase the university students’ well-being and raise their awareness on the prevention of internet addiction and healthy internet use.

A limitation of the study is the collection of data on the internet by online survey method. Another limitation of the study is that the data were obtained during the pandemic period.

In future studies, a larger sample can allow a generalization for the full mediating role of well-being by expanding the characteristics of the sample. New studies can be carried out to determine the factors other than well-being that have a full mediating role in internet addiction. Researchers can prepare psychoeducational programs to reduce internet addiction and conduct experimental/semi-experimental studies to determine the effectiveness of these programs.

Ethics Committee Approval: Ethics committee approval was received for this study from Scientific Research Ethics Committee, the registration number 68282350/20021/017, 17.

Informed Consent: Written consent form was obtained from the participants who agreed to participate in the study.

Peer-review: Externally peer-reviewed.

Author Contributions: Concept - A.U.B., A.G.; Design - A.U.B., A.G.; Supervision - A.U.B.; Data Collection and/or Processing - A.U.B., A.G.; Analysis and/or Interpretation - A.U.B., A.G.; Literature Review - A.U.B., A.G.; Writing - A.U.B., A.G.; Critical Review - A.U.B., A.G.

Declaration of Interests: The authors have declared that no conflicts of interest exist.

Funding: The authors declared that this study has received no financial support.

References

- Anglim, J., & Grant, S. (2016). Predicting psychological and subjective well-being from personality: Incremental prediction from 30 facets over the Big 5. *Journal of Happiness Studies*, 17(1), 59 – 80. [CrossRef]
- Asıcı, E. (2019). The predictive role of forgiveness resilience on adolescent well-being. *Erzincan Üniversitesi Eğitim Fakültesi Dergisi*, 21(3), 17 – 31. [CrossRef]
- Bandalos, D. L. (2002). The effects of item parceling on goodness-of-fit and parameter estimate bias in structural equation modeling. *Structural Equation Modeling: A Multidisciplinary Journal*, 9(1), 78 – 102. [CrossRef]
- Baron, R. M., & Kenny, D. A. (1986). The moderator-mediator variable distinction in social psychological research: Conceptual, strategic, and statistical considerations. *Journal of Personality and Social Psychology*, 51(6), 1173 – 1182. [CrossRef]
- Bozkurt, H., Şahin, S., & Zoroğlu, S. (2016). Internet addiction: A current review. *Journal of Contemporary Medicine*, 6(3), 1 – 13. [CrossRef]
- Burger, J. M. (2006). *Personality*. Istanbul: Kaknüs Publications.
- Butler, J., & Kern, M. L. (2015). The PERMA-Profil: A brief multidimensional measure of flourishing. *International Journal of Wellbeing*, 6(3), 1 – 48. [CrossRef]
- Cenkseven, F., & Akbaş, T. (2007). Üniversite öğrencilerinde özel ve psikolojik iyi olmanın yordayıcılarının incelenmesi. *Türk Psikolojik Danışma ve Rehberlik Dergisi*, 3(27), 43 – 65. <https://dergipark.org.tr/en/download/article-file/200206>.
- Cole, S. H., & Hooley, J. M. (2013). Clinical and personality correlates of MMO gaming: Anxiety and absorption in problematic internet use. *Social Science Computer Review*, 31(4), 424 – 436. [CrossRef]

- Costa, P. T., & McCrae, R. R. (1992). Four ways five factors are basics. *Personality and Individual Differences*, 13(6), 653 – 665. [CrossRef]
- Çelik, S., Atak, H., & Başal, A. (2012). Predictive role of personality traits on internet addiction. *Turkish Online Journal of Distance Education*, 13(4), 10 – 24. Retrieved from <https://dergipark.org.tr/en/pub/tojde/issue/16902/176198>.
- Davis, R. A. (2001). A cognitive-behavioral model of pathological internet use. *Computers in Human Behavior*, 17(2), 187 – 195. [CrossRef]
- Demirci, İ., Ekşi, H., Dinçer, D., & Kardaş, S. (2017). Five-dimensional model of well-being: The validity and reliability of the Turkish form of the PERMA scale. *Journal of Happiness and Well-Being*, 5(1), 60 – 77.
- Derin, S., & Bilge, F. (2016). Internet addiction and subjective well-being level in adolescents. *Turkish Journal of Psychological Counseling and Guidance*, 46(6), 35 – 51.
- Doğan, T. (2013). Five factor personality traits and subjective well-being. *Doğuş University Journal*, 14(1), 56 – 64. Retrieved from https://scholar.google.com.tr/scholar?hl=tr&as_sdt=0%2C5&q=Doğan%2C+T.+%282013%29.+Five+factor+personality+traits+and+subjective+well-being.+Do%2C%282013%29.+University+Journal
- Dong, G., Wang, J., Yang, X., & Zhou, H. (2013). Risk personality traits of internet addiction: A longitudinal study of internet-addicted Chinese university students. *Asia-Pacific Psychiatry*, 5(4), 316 – 321. [CrossRef]
- Dost, M. T. (2005). Mental health and subjective well-being. *Eurasian Journal of Educational Research*, 20, 223 – 231.
- Durak-Batgün, A., & Kılıç, N. (2011). İnternet Bağımlılığı ile Kişilik Özellikleri, Sosyal Destek, Psikolojik Belirtiler ve Bazı Sosyo-Demografik Değişkenler Arasındaki İlişkiler. *Turk Psikoloji Dergisi*, 26(67). <https://www.psikolog.org.tr/tr/yayinlar/dergiler/1031828/tpd1300443320110000m000093.pdf>
- Ekşi, F. (2012). Examination of Narcissistic Personality Traits' Predicting Level of Internet Addiction and Cyber Bullying through Path Analysis. *Educational Sciences: Theory and Practice*, 12(3), 1694 – 1706.
- Engelberg, E., & Sjöberg, L. (2004). Internet use, social skills, and adjustment. *Cyberpsychology and Behavior*, 7(1), 41 – 47. [CrossRef]
- Hardie, E. & Yi-Tee, M. (2007). Excessive internet use: the role of personality, loneliness and social support networks in internet addiction. *Australian Journal of Emerging Technologies and Society*, 5(1), 33 – 47.
- Gündüz, H. C., Ekşioğlu, S., & Tarhan, P. (2017). Problematic internet usage: Personality traits, gender, age, and effect of dispositional hope level. *Eurasian Journal of Educational Research*, 70, 57 – 82. [CrossRef]
- Karababa, A., Mert, A., & Çetiner, P. (2018). Üniversite öğrencilerinde psikolojik iyi olmanın bir yordayıcısı olarak benlik ayrımlaşması. *Ahi Evran Üniversitesi Kırşehir Eğitim Fakültesi Dergisi*, 19(2), 1235 – 1248. [CrossRef]
- Kaya, H. (2019). Evaluation of the relationship between asthenopic complaints and internet addiction in university students. *Pamukkale Medical Journal*, 12(3), 561 – 567. [CrossRef]
- Kaya, Z., İkiz, F. E., & Asıcı, E. (2016). Investigation of the relationship between problematic internet use and psychological symptoms of Science High School students. *International Journal of Human Sciences*, 13(1), 451 – 465. [CrossRef]
- Koch, W. H. ve Pratarelli, M. E. (2004). Effects of intro/extraversion and sex on social internet use. *North American Journal of Psychology*, 6(3), 371-382. [CrossRef]
- Kutlu, M., Savci, M., Demir, Y., & Aysan, F. (2016) Turkish adaptation of Young's Internet Addiction Test-Short Form: A reliability and validity study on university students and adolescents. *Anatolian Journal of Psychiatry*, 17(1), 69 – 76. [CrossRef]
- Landers, R. N., & Lounsbury, J. W. (2006). An investigation of Big Five and narrow personality traits in relation to internet usage. *Computers in Human Behavior*, 22(2), 283 – 293. [CrossRef]
- Little, T. D., Rhemtulla, M., Gibson, K., & Schoemann, A. M. (2013). Why the items versus parcels controversy needn't be one. *Psychological Methods*, 18(3), 285 – 300. [CrossRef]
- Lovett, N., & Lovett, T. (2016). Wellbeing in education: Staff matter. *International Journal of Social Science and Humanity*, 6(2), 107 – 112. [CrossRef]
- Meydan, C., & Şeşen, H. (2015). *Structural equation modeling AMOS applications*. Ankara: Detay Publishing.
- Morsunbul, U. (2014). The validity and reliability study of the Turkish version of quick big five personality test. *Dusunen Adam The Journal of Psychiatry and Neurological Sciences*, 27(4), 316. [CrossRef]
- Preacher, K. J., & Hayes, A. F. (2008). Asymptotic and resampling strategies for assessing and comparing indirect effects in multiple mediator models. *Behavior Research Methods*, 40(3), 879 – 891. [CrossRef]
- Seligman, M. E. P. (2002). *Authentic happiness*. New York, USA: Free Press.
- Serin, N. B. (2011). An examination of predictor variables for problematic internet use. *Turkish Online Journal of Educational Technology-TOJET*, 10(3), 54 – 62. Retrieved from <https://files.eric.ed.gov/fulltext/EJ944927.pdf>.
- Servidio, R. (2014). Exploring the effects of demographic factors, internet usage and personality traits on internet addiction in a sample of Italian university students. *Computers in Human Behavior*, 35, 85 – 92. [CrossRef]
- Taş, İ., & Ayas, T. (2015). Relationship the level of internet addiction with personality traits of high school students Lise öğrencilerinin internet bağımlılık düzeyinin kişilik özellikleriyle ilişkisi. *Journal of Human Sciences*, 12(2), 150-162. <https://www.j-humansciences.com/ojs/index.php/IJHS/article/view/3279>
- Turkish Statistical Institute (TUIK). (2019). *Use of information technologies in households*. Retrieved from http://www.tuik.gov.tr/PreTablo.do?alt_id=1028.
- Tuten, T. L., & Bosnjak, M. (2001). Understanding differences in web usage: The role of need for cognition and the Five Factor Model of personality. *Social Behavior and Personality: An international journal*, 29(4), 391-398. [CrossRef]
- Uz Baş, A. (2018). Comparative analysis of psychological well-being, resilience and communication skills of guidance and psychological counseling department students with university students studying in different departments. *Journal of Academic Social Science Studies*, 66(2), 1 – 9.
- Uz Baş, A., Soysal, F. S., & Aysan, F. (2016). The relationship between problematic internet use and psychological well-being and social support in university students. *ITOBİAD: Journal of the Human & Social Science Researches*, 5(4), 1 – 12. Retrieved from <http://www.itobiad.com/en/download/article-file/206384>.
- Yang, S. Y., & Kim, H. S. (2018). Effects of a prevention program for internet addiction among middle school students in South Korea. *Public health nursing (Boston, Mass.)*, 35(3), 246 – 255. [CrossRef]

Genişletilmiş Özet

Giriş

Günümüzde internetin her yaşta birey için erişiminin ve kullanımının oldukça yaygınlaştığı görülmektedir. İnterneti sağlıklı ve bilinçli kullananlar için yararları ön planda iken, interneti amacı dışında ve bilinçsizce kullananlar için zararları söz konusudur. Yapılan çalışmalarda internet kullanım süresinin üniversite gençleri arasında oldukça fazla olduğu ortaya konmuştur. İnternetin bir diğer olumsuz sonucu olan internet bağımlılığı ilk sırada yer alan önemli bir sorun olarak görülmektedir. İnternet bağımlılığı eylemsel bağımlılıklar içerisinde yer alan ve maddesel bağımlılık türlerinde gösterilen semptomlara benzer özellikler gösteren bir problem olarak adlandırılır. İnternetin bağımlılık haline dönüşmesinde önemli faktörlerden birinin yukarıda bahsedilen kullanım süresi olduğu belirtilirken, bir diğerinin ise internetin amacı dışında kullanılmasının olduğu belirtilmektedir.

İnternet bağımlılığında etkili olan faktörlerden bir diğerinin ise kişilik özelliklerinin olduğu ifade edilmektedir. McCrea ve Costa'nın geliştirdiği Beş faktör kişilik kuramı, dışadönüklük, nevroitiklik (duygusal denge), uyumluluk, deneyime açıklık ve sorumluluk boyutlarından oluşmaktadır. Beş faktör kişilik kuramı temele alınarak problemlili internet kullanımı ile ilgili alan yazında yapılan çalışmalarda farklı sonuçların elde edildiği görülmektedir. Bir çalışmada kişilik özelliklerinden sabit fikirli olmanın da problemlili internet kullanımı davranışında etkili olduğu ortaya çıkmıştır. Bir başka çalışmada internet bağımlılığı ile deneyime açıklık, uyumluluk, öz disiplin ile negatif; nevroitiklik ile pozitif yönde ilişki bulunmuştur. Ayrıca internet bağımlılığının duygusal denge ve nörotizm boyutları ile yakından ilişkili olduğu belirtilmektedir. İnternet bağımlılığı aynı zamanda bireyin psikolojik iyi oluşu ile de ilgili bir durumdur.

İyi oluş pozitif psikoloji alan yazında ön plana çıkmış bir kavramdır. İyi oluş kavramının alan yazında farklı şekillerde tanımlandığı görülmektedir. Bu tanımlarda öne çıkan model, Martin Seligman'ın Çok Boyutlu İyi Oluş Modeli'dir. Seligman'a göre iyi oluş farklı boyutların bir araya gelerek yeni bir bütün oluşturmasıdır. O'na göre iyi oluşu beş boyut ile tanımlamak gerekir: Olumlu duygular, bağlanma, olumlu ilişkiler, anlam ve başarı. Alan yazında yapılan çalışmalarda iyi oluşun bireyin kişilik özellikleri ile ilişkili olduğu bulunmuştur. Bireyin iyi oluşunu internet kullanımı davranışını da etkileyebildiği belirtilmektedir. İnternetin olumsuz sonuçları ile ilgili yapılan araştırmalar ve bu çalışmaların sonuçlarına bağlı olarak mevcut araştırmada bireyin kişilik özellikleri ile internet bağımlılığı ilişkisinde iyi oluşunun aracılık rolünün ortaya çıkarılması amaçlanmıştır.

Yöntem

Mevcut araştırma nicel araştırma yaklaşımıyla yürütülmüş, ilişkisel tarama modeline göre yapılmış betimsel bir araştırmadır. Araştırma örneklemini 2019-2020 Eğitim Öğretim yılında lisans eğitimine devam eden ve uygun örnekleme yöntemi ile Çocuk Gelişimi, Psikolojik Danışmanlık ve Rehberlik (PDR) bölümlerinden seçilmiş toplam 452 öğrenciden oluşmaktadır. Araştırmada, kişisel Bilgi Formu, Young İnternet Bağımlılığı Testi Kısa Formu (YIBT-KF), PERMA Ölçeği, Hızlı Büyük Beşli Kişilik Testi (HBBKT) ölçekleri kullanılmıştır.

Bulgular

Araştırmada değişkenlerin normal dağıldığı (basıklık ve çarpıklık katsayısına göre) belirlenmiştir. Korelasyon katsayıları incelendiğinde iyi oluşun, uyumluluk ($r = .59, p < .01$), sorumluluk ($r = .51, p < .01$), duygusal dengelilik ($r = .29, p < .01$), deneyime açıklık ($r = .44, p < .01$) ile pozitif yönde ilişkili olduğu görülmektedir. İyi oluşun internet bağımlılığı ($r = -.41, p < .01$) ve internet bağımlılığının uyumluluk ($r = -.22, p < .01$), dışa dönüklük ($r = -.09, p < .01$), sorumluluk ($r = -.33, p < .01$), duygusal dengelilik ($r = -.28, p < .01$), deneyime açıklık ($r = -.13, p < .01$), değişkenleri ile negatif yönde ilişkili olduğu tespit edilmiştir. Yapılan yapısal eşitlik modelinde sonuçların kabul edilebilir düzeyde olduğu ($\chi^2/SD = 4.97, p < .01$, RMSEA = .09, SRMR = .05, GFI = .93, NFI = .94, TLI = .93, CFI = .95) belirlenmiştir. Yapılan analizlere göre kişilik özellikleri iyi oluşu pozitif yönde ($\beta = .79, p < .01$), iyi oluşun da internet bağımlılığını negatif yönde ($\beta = -.51, p < .01$) yordadığı belirlenmiştir. İyi oluş aracı değişkeni modele eklendiğinde ise kişilik özelliklerinin internet bağımlılığını yordama gücünün ($\beta = .06, p < .01$) ortadan kalktığı gözlenmiştir. Başka bir ifadeyle kişilik özellikleri iyi oluş aracı değişkeni üzerinden internet bağımlılığını anlamlı düzeyde yordadığı görülmektedir. Bootstrapping işlemi sonucunda elde edilen değerlere de bakıldığında doğrudan yol katsayılarının anlamlı olduğu görülmektedir. Bununla birlikte dolaylı yol ilişkilerinin de anlamlı olduğu görülmektedir ($\beta = -.40, \%95 \text{ G.A.} = -.61 \text{ to } -.21$). Bu sonuçlara göre iyi oluşun kişilik özellikleri ile internet bağımlılığı arasında tam aracı rolünün olduğu söylenebilir.

Tartışma

Elde edilen sonuçlara göre iyi oluşun kişilik özellikleri ile internet bağımlılığı arasındaki ilişkide tam aracı rolünü üstlendiği görülmüştür. Diğer bir ifadeyle kişilik özellikleri bireyin iyi oluş düzeyinin düşmesine; iyi oluş düzeyinin düşmesi ise bireyin internet bağımlılığı düzeyinin yükselmesine neden olmaktadır.

Mevcut araştırmada kişilik özelliklerinden uyumluluk, sorumluluk, duygusal denge, deneyime açıklık alt boyutları ile internet bağımlılığı arasında negatif yönde bir ilişki gözlemlenirken, dışa dönüklük ile internet bağımlılığı arasında herhangi bir ilişki gözlemlenmemiştir. Yapılan çalışmaların bazılarında internet bağımlılığı ile dışa dönüklük kişilik özelliği arasında pozitif yönde bir ilişki elde edilirken, bu sonuçla örtüşmeyen sonuçların elde edildiği çalışmalar da bulunmaktadır. Diğer bir ifadeyle dışadönüklük kişilik özelliği

ile internet bağımlılığı arasında negatif yönde ilişki bulunduğunu gösteren çalışmaların olduğu görülmektedir. Ayrıca mevcut araştırmada dışa dönüklük ile internet bağımlılığı arasında bir ilişki bulunmadığı; deneyime açıklık ile internet bağımlılığı arasında negatif yönde bir ilişki olduğu görülmektedir. Deneyime açıklık ile internet bağımlılığı arasında negatif yönde bir ilişki olduğu sonucunu elde eden çalışmalar olduğu gibi, deneyime açıklık ile internet bağımlılığı arasında pozitif yönde ilişki olduğunu ortaya koyan çalışmalar da bulunmaktadır. Kişilik özelliğinin diğer bir alt boyutu olan içedönüklük ile internet bağımlılığı arasında pozitif yönde bir ilişki olduğunu ortaya koyan çalışmalar bulunmaktadır. Mevcut araştırmada uyumluluk ile internet bağımlılığı arasında negatif yönde bir ilişki bulunmuştur. Uyumluluk ile internet bağımlılığı arasında negatif yönde ilişki olduğunu ortaya koyan çalışma olduğu gibi, uyumluluk ile internet bağımlılığı arasında pozitif yönde ilişki olduğunu ortaya koyan çalışmalar da bulunmaktadır. Alan yazında nörotizm ile internet bağımlılığı arasında pozitif yönde bir ilişki olduğu sonucun elde eden çalışmalar olduğu gibi, negatif yönde ilişkili olduğunu elde eden çalışmaların da olduğu görülmektedir. Mevcut araştırmada duygusal denge ile internet bağımlılığı arasında negatif yönde bir ilişki bulunmuştur. Duygusal denge ile internet bağımlılığının negatif yönde ilişkili olduğu bulunmuştur.

Mevcut çalışma sonuçlarına göre ileride yapılacak çalışmalar için şu öneriler verilebilir: Alanda çalışıp psikolojik destek hizmeti sunan psikolojik danışmanlar; bireylerin iyi oluş düzeylerinin artmasına yönelik psikoeğitim programları hazırlayabilir, bireysel ve grup çalışmaları yapabilir. Konuyla ilgili araştırmaya yapmak isteyen araştırmacılar için şu öneriler verilebilir: Araştırmacılar internet bağımlılığının azaltılmasına yönelik psikoeğitim programları hazırlayıp, bu programların etkililiğinin belirlenmesine yönelik deneysel/yarı deneysel çalışmalar planlayabilirler. Çalışmanın verilerinin iki üniversitede iki bölümdeki öğrenci örneklemeden elde edilmiş olması çalışmanın önemli bir sınırlılığıdır. Araştırmanın bir diğer sınırlılığı ise araştırma verileri ölçeklerden elde edilen bilgiler ile sınırlıdır.