



# The Role of Perceived Ease of Use and Perceived Usefulness on Personality Traits among Adults

**HURSIT CEM SALAR**

**NAZIRE BURCIN HAMUTOGLU**

\*Author affiliations can be found in the back matter of this article



RESEARCH ARTICLE

## ABSTRACT

It has been suggested that individuals' technology acceptance are affected by personality traits. This paper aims to emphasise the importance of personality traits beyond BIG 5 on the acceptance and individual usage of Cloud Computing Systems (CCSs) with Perceived Ease of Use (PEU) and Perceived Usefulness (PU). Based on this, a quantitative cross-sectional survey research was designed, and 722 students studying at Sakarya University, Pedagogical Training Certification Program in the academic year of 2016–2017 were involved to the study. A path analysis which is a structural equation model was performed to examine the direct and indirect effects of the variables that are theoretically interrelated in the study. According to the results, while Extroversion (EXT), Agreeableness (AGR), Conscientiousness (CONS), and OE are not predictors of PEU and PU components, Nervousness (NEUR), is a significant predictor of PEU in the model. In addition to this, behavioural intention (BI) is significantly predicted by both PU and PEU, and PEU is a significant predictor of PU and BI on the individual usage of CCSs.

## CORRESPONDING AUTHOR:

**Hursit Cem Salar**

Pamukkale University, Turkey

[csalar@pau.edu.tr](mailto:csalar@pau.edu.tr)

## KEYWORDS:

Acceptance; BIG 5; cloud computing systems; personality traits; TAM

## TO CITE THIS ARTICLE:

Salar, H. C., & Hamutoglu, N. B. (2022). The Role of Perceived Ease of Use and Perceived Usefulness on Personality Traits among Adults. *Open Praxis*, 14(2), pp. 133–147. DOI: <https://doi.org/10.55982/openpraxis.14.2.142>

In the process of integrating new technologies into the 21st century education curricula and classrooms, educators might face a number of challenges which require the use of practical approaches such as pedagogical knowledge. The integration of new technologies is important for ensuring effective and sufficient outcomes. Accordingly, this integration is also important for educational process. Several studies discuss the effectiveness of pedagogical practice trends on emerging technologies (Kalogiannakis, 2010; Pearson & Naylor, 2006; Tsai & Chai, 2012; Windschitl, 2002). Although there is considerable evidence to emphasize the role of teachers' pedagogical beliefs in using new technologies in the classroom (Hermans et al., 2008; Prestridge, 2010), it is also important to keep in mind that their approach should be appropriate in implementing these technologies.

Cloud computing systems (CCSs) are one of the most popular emerging technologies available in the field of education. They are considered as a new type of technology which significantly affects teaching and learning processes in educational environments (Alajlan et al., 2022; Li, 2016; Utami et al., 2022). Zoho, Microsoft 365 cloud applications, and Google applications for education are becoming increasingly popular in educational institutions. Today, Monash University, Brown University, University of Benin, many K-12 schools and Departments of Education like Vanderbilt University use the educational version of Google applications (Google Apps for Education, 2015). It seems that to succeed in this, acceptance and individual usage should be taken into account, whereas keeping up with the technology is important in education. Especially the teachers' acceptance of CCSs will be affected by their future usage. The work done by Utami et al. (2022) during the covid 19 pandemic process clearly supports this asserted situation. To illustrate this issue, Pearson and Naylor (2006) discuss the changing roles of teachers as one of the key themes of integration of the emerging technologies into education. CCSs support the active usage in the classrooms, due to the changing roles between teachers and students (Anshari et al., 2015; Huang et al., 2013). For example, Google applications can be used in many cooperative works such as preparing slides, tables, translations, calendar, as well as in communications (e.g. Gmail). Furthermore, the implementation of CCSs in education facilitates the interoperability of different tools, as well as collaborative work. This can be achieved through successful integration of complex components (Garcia-Penalvo et al., 2014). Recent studies demonstrate how contextual factors can influence diffusion and adoption of cloud computing into the educational environments (Alajlan et al., 2022; Li, 2016). Considering the changing roles of teachers and the contextual factors of CCSs integration, the importance of personality traits of using the technology is emphasized in this paper. Personality differences affect the usage of technologies in the classroom. For example, a person who is not open to new approaches, technologies and pedagogies and keeps on using traditional methods will have different personal traits from the one who tends to use new technologies in the classroom. Previous studies suggest that, while adapting a new technology, individual differences such as culture, personality, and familiarity with technology, level of education, socio-economic and cultural status, and intrinsic and extrinsic motivation might have a significant impact on technology acceptance (Agarwal & Prasad 1999; Devaraj et al., 2008; Srite & Karahanna 2006; Venkatesh et al., 2003). Although the successful adoption of new technologies is more likely to improve effective learning, this paper also discusses how the individual acceptance and usage of trend technologies differs from personality traits beyond Big 5.

According to psychologists, personality traits are related to personal factors and they vary depending on different angles or dimensions (Allport, 1961). Eysenck (1991) puts forward that personality traits include five different factors: comprehensiveness, replicability, external correlates, source traits, and multiple levels. These factors are called BIG 5 and are also known as Five Factor model (FFM) (Costa & McCrae, 1992). BIG 5 has received considerable attention that categorises the personality traits into Extroversion (EXT), Conscientiousness (CONS), Agreeableness (AGR), Neuroticism (NEUR), and Openness to Experience (OE) (Costa & McCrae, 1992; Digman, 1990; Goldberg, 1992). These principles of personality traits seem to relate to the individual usage and acceptance of the CCSs technology. With the basis of related literature, it is believed that individuals with different personalities will also behave differentiate in the use and acceptance of these kinds of technologies.

Individual differences are used as an underlying theoretical framework in relation with the cognitive determinants such as Rogers' relative advantage and compatibility (1995), and Davis' ease of use (1989) for adopting internet technologies (Arts et al., 2011; Dwivedi et al., 2011; Moore & Benbasat, 1991; Venkatesh & Susan, 2001). It has also been seen in a number of studies which investigate the personality differences via BIG 5 and technology acceptance models of Technology Acceptance Model (TAM) and Unified Theory of Acceptance and Use of Technology (UTAUT). Xua et al. (2016) compared how the adoption of different mobile apps (social, gaming shopping, photography, personalization, music & video, and finance) depends on the personality adopters, according to BIG 5. Bai et al. (2013) investigate BIG 5 personality traits of Microblog users. Kelly and James (2012) and Correa et al. (2010) researched the influence and the relationship of the use of social networking based on users' Big Five personality. Jeong and Kim (2016) demonstrated the predictive utility of the individual differences such as computer self-efficacy (CSE), subjective norm (SN) and personal innovativeness in educational technologies (PIET) factors. Among a sample of 160 kindergarten teachers, CSE was independently predicted by PEOU and BI; SN was independently predicted by PU, and finally PIET was independently predicted by CSE and SN, the variables of TAM. Li (2016) analyses the predictive utility of BIG 5 such as the positive influence of conscientiousness on perceived usefulness (PU). Additionally, extraversion and agreeableness moderate the influence of subjective norms on perceived usefulness, while openness to experience moderates the relationship between training and perceived usefulness by TAM. Nistor et al. (2013) worked on the impact of national and professional culture across the educational technology acceptance with the UTAUT model. Wang and Yang (2005) mainly examine the roles that personality traits play in UTAUT model under the context of online stocking. Also, Barnett et al. (2015) exerted within in the conceptual framework of UTAUT model with the FFM personality traits and in the context of a web-based classroom technological system, by measuring perceived and actual use of technology. Alajlan et al. (2022) proposed a model includes the theory of motivation, the theory of technology acceptance model and characteristics of cloud computing to measure the effectiveness of the e-learning system to identify the significant factors required to encourage students to keep using it. Results show the perceived ease of use and extrinsic motivation are significant factors that means have high effects on the intention to use. Considering the relation between motivation and achievement it is also believed that personality traits may be a significant factor to encourage students and effect the acceptance and usage. Accordingly, in the study of Kuba (2014) it is reported that achievement motivation correlates with conscientiousness. Addition to this, Kaufman et al. (2008) founded that conscientiousness is connected with better learning outcomes. Marino et al. (2018) also indicate the relation between self-regulation of learning and the personality traits.

The recent research has investigated the factors related with technology acceptance models and personality traits on different technologies. Most of the studies have employed qualitative and quantitative methods. The previous studies demonstrated that personality traits have an important role in the acceptance of different technologies. However, the studies on how personality traits beyond BIG 5 and the interactions with the variables of TAM influence an individual's perception and behaviour intention on CCSs have received scant attention. How the personality traits would affect the intention to accept a new technology has not reached final conclusions (Wang & Yang, 2005). Specifically, the purpose of this study is to consider a more important role of personality traits in the individual acceptance and usage of CCSs technology with the main components of individual acceptance and usage. The main contributions of this paper are as follows: This study addresses directly the relationship between personal traits and cloud computing systems. Some studies which examine the relationship personal traits and technology (Wang & Yang, 2005; Devaraj et al., 2008; Punnoose, 2012; Özbek et al., 2014; Barnett et al., 2015; Li, 2016; Xua et al., 2016; Lu, Papagiannidis & Alamanos, 2019; Maican et al., 2019). However, it is seen that, except one study (Özbek et al., 2014), the other studies do not directly focus on these two subjects together. Özbek et al. (2014) focuses on personality traits within the framework of TAM considering smartphones users while Maican et al. (2019) analyse the attitudes and perceptions of academic staff's personality and technology acceptance considering the communication and collaboration applications. In this sense, it can be said that there is limited study which examines directly the relationship between personality traits and cloud computing systems although many studies on personality traits and technology have been made so far. On the other hand, it is seen that personality traits term has been studied

inter-disciplinarily (Klein, 2010) with the improvement of technology although it was studied only psychologically (McCrae & Costa, 1997) before. However, this situation has shown that there is a gap in cloud computing systems in terms of personal traits in literature. As it is known, today's business have more horizontal organization structure types such as hybrid, network, joint ventures, loan, clustered, self-managing working groups (Aksay, 2015). Rivers (2021) examines the role of personality and online academic self-efficacy in acceptance, actual use and achievement in Moodle and founded that agreeableness and conscientious have positive and positive indirect effects on the acceptance of Moodle. The common feature of these organization types is that the workflow runs horizontally rather than vertically. This situation creates a more dynamic and speed workflow. Therefore, the technological improvements which facilitate and speed up work processes are preferred densely. At this point, it can be said that cloud computing system is a very facilitator and dynamic work tool. Because some companies such as Google, Microsoft, etc. have network structure and many employees work in different places separately. The systems of these companies based on cloud computing systems which enable to employees work on the same document and share it with collaborators. Based on these, it is possible to assert that these companies have different working areas and their working environments are structured by taking into account the different personality structures. In Turkey, most of the institutions move their systems into cloud computing systems, and Turkey is among the countries that consider the employees' personality differences since interacting with Google, Azure, Amazon, 365 etc. such cloud systems in educational environment. Apart from these profit companies, it can be said that non-profit companies do not look for money-based, but also not for pedagogy. Therefore, the pedagogical part of the section that is important for companies is missing. Imagine that the teacher has an extroverted structure, preferring to use technology that allows interaction within the classroom, and may prefer to apply technology that reduces the interaction of an inward-oriented teacher to one-to-one. This suggests that the type of personality of the teacher may affect the use and acceptance of technology. Therefore, in this study, it was found appropriate to work with teacher candidates in the opinion that the teacher will shape the students' educational life. In this context, it can be thought that having these different personality traits has an effect on the use and adoption of developing technology. In other words, it is possible that a technological development which is not suitable for the personality type of teacher will not be preferred by individuals. In this context, it is claimed that this study is suitable for a modern work understanding. It is seen that CCSs are not made in the order in which the network organizations spread in the developing and changing world order especially when the universities in a non-profit company, and from a pedagogical point of view, and working through cloud systems. Therefore the problems of the study is as following:

1. What is the direct and indirect effects of principle factors of BIG 5 on PEU, PU, and BI in assessing the use of CCSs in education?
2. What is the direct and indirect effects of PEU on PU and BI assessing the use of CCSs in education?
3. What is the effect of PU on BI assessing the use of CCSs in education?

## CHARACTERISTICS OF DIFFERENT PERSONALITY TRAITS

In this section, personality traits are discussed to highlight the differences among extroversion, conscientiousness, agreeableness, nervousness, and openness to experience.

### EXTROVERSION

Extroverts are more likely to be in a crowded environment and keen on willing to take risks (Eysenck, 1991). They are more positive and optimistic, and they are more involved in social activities, and tend to look for amusement. Moreover, extroverts are more assertive, social and demonstrative (Goldberg, 1992). They are more around and keen on manoeuvring the new technologies. Extroverts do not only care about their images, but also their behaviour in the social consequences (Devaraj et al., 2008). Self-efficacy and high energy makes them join self-managed working groups more easily than others (Thoms et al., 1996). Individuals with high level of this trait are energetic, grave, friendly, outgoing and enjoy being with others (Costa & McCrae, 1992; McCrae & John, 1992; Sanders, 2008).

## CONSCIENTIOUSNESS

Individuals who are conscientious are more likely to take responsibility and have an authoritative, meticulous and thoughtful approach (Eysenck, 1991). Individuals who possess a high level of this trait are well organized, trustable, comprehensive, and exacting (Goldberg, 1992). Achievement, constancy and regularity are what they need (Costa, McCrae, & Dye 1991). They are highly shifted and intrinsically motivated at their work (Barrick & Mount, 2000). The individuals with that trait obey the rules, take responsibilities, are dependent, well oriented, and detailed and they have a sense of achievement. They also like to plan ahead (Costa & McCrae, 1992; McCrae & John, 1992; Sanders, 2008).

## AGREEABLENESS

Agreeable individuals seem more cordial and enthusiastic (Eysenck, 1991). They tend to help other people and are very keen on sympathizing with others. Costa et al. (1991) indicate that the individuals with this trait are altruistic and adaptable. Additionally, agreeableness is related with humility, docility, and straightforwardness, and these people are guided by feelings, particularly those of sympathy in making judgments and forming attitudes. This trait refers to an individual who has inter-personal relationships and tends to be friendly, helpful, thoughtful, accommodating, tries to avoid conflict, is co-operative, forgiving and trusted (Costa & McCrae, 1992; McCrae & John, 1992; Sanders, 2008).

## NERVOUSNESS

Nervous individuals are more likely to be relatively unstable (Eysenck, 1991). It is easy to fright them, and they easily become rushed, depressive and angry. Theoretical framework of a nervous person is under social pressure, and is likely to develop certain behaviour. The individuals who have low level of neuroticism or high level of emotional stability are self-confident, secure, well audited, not easily disturbed, and resilient. Individuals with this trait apparently finish difficult tasks in less time. Additionally, individuals who score high in neuroticism are likely to feel insecure, discontented, sensitive to ridicule, shy and easily embarrassed (Costa & McCrae, 1992; McCrae & John, 1992; Sanders, 2008). Also, negative events can have a deep emotional effect on them (Heller et al., 2002).

## OPENNESS TO EXPERIENCE

Open individuals have much more imagination than others and more often tend to express one's curiosity. The individuals who have high scores in this trait tend to be cognitively explorative, cognitively flexible, and divergent thinkers (DeYoung et al., 2005). Conversely, people who tend to be conventional in behaviour and conservative in outlook have low traces of this trait. This style of personality traits refers to the abilities to accept various experiences and cultures. As shown in the studies of Saadé et al. (2006), users' acceptance and performance of new information and communication technologies usage depends strongly on behavioural and personality traits such as perceptions, attitudes, openness to experiment, or ones willingness to simply try new things. Additionally, they state that the acceptance of a new technology is dependent on several of constructs; mainly computer skill, beliefs and self-efficacy. Especially in this study, the different personality traits might have an important role in integrating the new technologies in education. This trait refers to persons open to learning, innovation, and change. They also tend to be curious, and intelligent, and like to try new ideas (Costa & McCrae, 1992; McCrae & John, 1992; Sanders, 2008).

## METHOD

This study was designed with relational survey model which is a quantitative research method. In this context, path analysis technique which is a structural equation model was used. Therefore, a model was formed which addressed the relationships between BIG5 personality types and the components of TAM.

## PARTICIPANTS AND PROCEDURES

Participants were 722 students studying at Sakarya University, Pedagogical Training Certification Program in the academic year of 2016–2017, of whom five hundred and eighty-four were female (80.9%). This certification program aims to strength life-long learning tendency for the university students who are already studying in a program or graduated a faculty, and have already a job, and their jobs are completely related with computers. The certification program included pedagogical courses in the parallel of education faculties' program and includes 10 theoretical and practical course related with education pedagogy. Although the sample was a convenience sample, considering the dynamic of the universities and local placed of the university -which is on the west south part of the most crowded city in Turkey- it is possible to say the sample represents the universe regarding the data come from the participants.

## PROCESS

The aim of this study is to investigate the effect of the BIG5 personality types on the components of TAM, PEU and PU. In order to investigate this issue, the valid variables obtained were prepared to get results. A path analysis which is a structural equation model was performed to examine direct and indirect effects of the variables that are theoretically interrelated in the study. Mahalanobis distance, Variance Inflation Factor (VIF) and Tolerance values and multicollinearities of the independent variables are checked. Mahalanobis distance values were determined by taken the Chi-Square table into account, with the degree of six independent variables freedom ( $p < 0.01$ , 16.812). All the statistical analyses were administered using the AMOS 20 and SPSS 20 software. The tested model is shown in Figure 1.

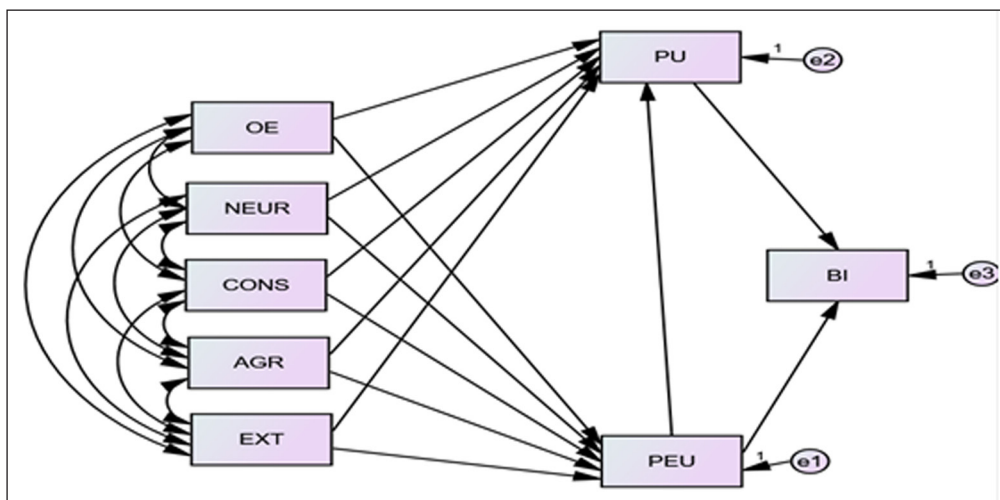

**Figure 1** The path analysis based on personality traits and PU, PEU, and BI.

## INSTRUMENTS

### Technology Acceptance Model 3: The Components of PEU and PU

The TAM3 was developed by Venkatesh and Bala (2008). The whole scale includes 50 items rated on a 7-point scale ranging from 1 “Strongly Disagree” to 7 “Strongly Agree” (4- Neutral), and an open-ended question. The scale is adapted to Turkish by Hamutoglu (2018) and the results of adaptation (EFA, CFA, Invariances design) show good psychometric properties and convergent validity and reliability as reported in the study. Turkish adaptation of TAM3 scale has 45 items with 7 Likert type-scale and 11 dimensions. In this study only PEU, PU and BI components were used to determine the effects of personality traits. While PEU and PU component consist four items, BI comprise with three items. Therefore, while the lowest score that can be obtained from the dimension of PEU and PU is 4, and the highest score is 28, and for the BI dimension is 3 and 21, respectively.

### BIG 5

The BIG 5 inventory is a 5-point Likert scale, comprising 10 items within the 5 dimensions as follow: extroversion, agreeableness, conscientiousness, neuroticism, and openness to experience, each of whom includes two items. BIG 5 was developed by Gosling et al. (2003),

and adapted to Turkish by Gunel (2010). The internal consistency of the extroversion is .89, agreeableness is .80, conscientiousness is .76, neuroticism .71, and openness to experience is .69 as indicated in Gunel’s research (2010). Therefore, the lowest score that can be obtained from each of the dimension of BIG 5 is 2, and the highest score is 10.

For the purposes of the study, the descriptive statistics and the fit indices results and are given in Tables 1 and 2, respectively.

VARIABLES	N	MIN	MAX	MEAN	STD. DEVIATION	SKEWNESS	KURTOSIS
PU	722	4	28	21.13	5.62	-0.784	0.264
PEU	722	4	28	19.84	5.20	-0.410	-0.184
BI	722	3	21	15.89	4.01	-0.622	0.026
EXT	722	2	10	7.54	1.76	-0.297	-0.614
AGR	722	4	10	7.99	1.43	-0.481	-0.364
CONS	722	4	10	7.90	1.60	-0.359	-0.679
NEUR	722	2	10	5.70	1.76	0.140	-0.378
OE	722	3	10	6.98	1.71	-0.021	-0.658

**Table 1** Descriptive Statistics of the Variables.

PU: Perceived usefulness, PEU: Perceived ease of use, BI: Behavioural intention, EXT: Extroversion, AGR: Agreeableness, CONS: Conscientiousness, NEUR: Neuroticism, and OE: Openness to Experience.

FIT CRITERIA	PERFECT FIT VALUES	ACCEPTABLE FIT VALUES	ACHIEVED FIT VALUES
( $\chi^2/df$ )	≤3	≤4–5	0.33
AGFI	≥0.90	≥0.85	0.99
GFI	≥0.90	≥0.85	0.99
CFI	≥0.97	≥0.90	1
RMSEA	≤0.05	0.06–0.08	0.000
SRMR	≤0.05	0.06–0.08	0.006

**Table 2** Perfect and Acceptable Fit Values regarding the Path Analysis.

Table 1 shows descriptive statistics of the variables such as sample size, mean, standard deviation, and minimum-maximum, and skewness-kurtosis values.

According to the fit values in Table 2, the model has acceptable and perfect fit values ( $\chi^2/sd = 0.33$ ; RMSEA = 0.000; SRMR = 0.006; CFI = 1; GFI = 0.99; AGFI = 0.99) (Baumgartner & Homburg, 1996; Bentler & Bonett, 1980; Bollen, 1990; Browne & Cudeck, 1993; Byrne, 2001; Hu & Bentler, 1999; Joreskog & Sorbom, 1993; Kline, 2011; Marsh et al., 2006; Steiger, 2007; Schermelleh-Engel & Moosbrugger, 2003; Tanaka & Huba, 1985). The developed and test path analysis is shown in Figure 2. The information on direct and indirect effects on the variable tested in the model is provided in Table 3.

It is seen in the model that while NEUR has a direct and negative effect on the “PEU” ( $\beta = -0.08$ ,  $p < 0.05$ ), and has not a significant predictors of “PU” ( $\beta = -0.02$ ,  $p > 0.05$ ). On the other hand, EXT, AGR, CONS, and OE are not significant predictors of “PEU” ( $\beta = 0.05$ ,  $p > 0.05$ ), ( $\beta = 0.05$ ,  $p > 0.05$ ), ( $\beta = 0.02$ ,  $p > 0.05$ ), ( $\beta = 0.05$ ,  $p > 0.05$ ), and “PU” ( $\beta = 0.02$ ,  $p > 0.05$ ), ( $\beta = -0.01$ ,  $p > 0.05$ ), ( $\beta = 0.04$ ,  $p > 0.05$ ), ( $\beta = -0.02$ ,  $p > 0.05$ ), ( $\beta = -0.05$ ,  $p > 0.05$ ), respectively. Moreover, “PEU” has a direct and positive effect on the “PU” ( $\beta = 0.44$ ,  $p < 0.001$ ), and “BI” is significantly predicted by both “PEU” and “PU”, respectively ( $\beta = 0.20$ ,  $p < 0.001$ ), ( $\beta = 0.32$ ,  $p < 0.001$ ). The dependent variable of PEU was explained by the independent variables of NEUR 2% ( $R^2 = 0.02$ ). In addition, the independent variable of PEU alone explained PU at 20% ( $R^2 = 0.20$ ), and the independent variables of PEU and PU explained BI at 20% ( $R^2 = 0.20$ ). Accordingly, it can be argued that NEUR had a small effect size even though it was a significant variable explaining PEU. On the other hand, PEU and PU had a moderate effect on BI, and similarly, PEU had a moderate effect on PU.

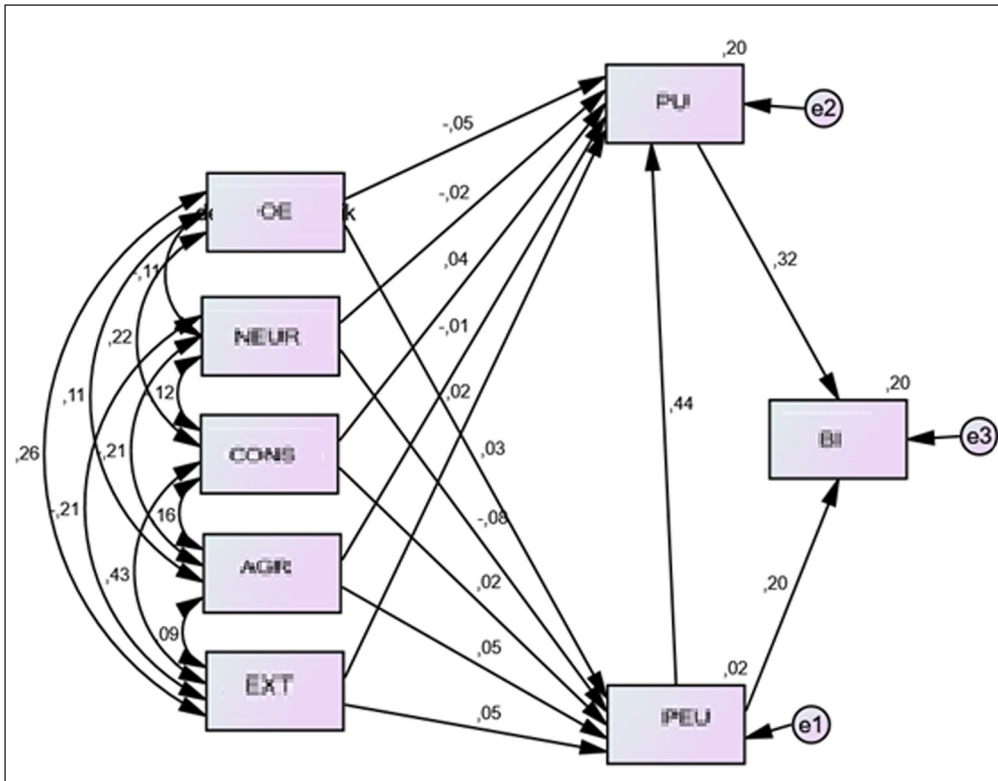

**Figure 2** Findings Achieved in the Path Analysis.

INDEPENDENT VARIABLE	DEPENDENT VARIABLE	TOTAL EFFECT	DIRECT EFFECT	INDIRECT EFFECT	STANDARD ERROR	CRITICAL RATIO (T)
EXT	PEU	0.046	0.046	-	0.124	1.094
AGR	PEU	0.046	0.046	-	0.138	1.207
CONS	PEU	0.018	0.018	-	0.135	0.434
NEUR	PEU	-0.076	-0.076	-	0.114	-1.965*
OE	PEU	0.29	0.29	-	0.117	0.758
PEU	BI	0.344	0.203	0.141	0.029	5.473***
PU	BI	0.319	0.319	-	0.026	8.592***
PEU	PU	0.442	0.442	-	0.036	13.156***
EXT	PU	0.043	0.023	0.020	0.121	0.595
AGR	PU	0.006	-0.015	0.020	0.135	-0.429
CONS	PU	0.050	0.042	0.008	0.132	1.121
NEUR	PU	-0.054	-0.020	-0.033	0.111	-0.583
OE	PU	-0.37	-0.050	0.013	0.114	-1.432
EXT	BI	0.023	-	0.023	-	-
AGR	BI	0.011	-	0.011	-	-
CONS	BI	0.020	-	0.020	-	-
NEUR	BI	-0.033	-	-0.033	-	-
OE	BI	-0.006	-	-0.006	-	-

**Table 3** Direct and Indirect Effects on the PU, PEU, and BI Variables.

\*  $p < 0.05$ ; \*\*  $p < 0.01$ ;  
 \*\*\*  $p < 0.001$ .

## DISCUSSION AND CONCLUSION

This study aimed to investigate individuals' (N = 722) acceptance and individual usage of cloud computing systems (CCSs) in education through their personality traits. The participants were enrolled in the pedagogical certificate program of Sakarya University. As expected, the results indicate the link between the acceptance and individual usage of the cloud computing systems and individual differences. To determine this relationship, PU and PEU –components



of TAM 3), and BIG 5 were used. It is also emphasized and suggested in recent studies that the acceptance of educational technologies in general require the consideration of individual differences (Kamyab & Delafrooz, 2016; Nistor et al., 2013). Our findings confirm this in case of the use of cloud computing in education specifically.

The findings of this study contribute to the field of educational computer systems as follows:

1. As a result of this study, it has been seen that personality traits affect the acceptance of technology, but this effect is very little (%2). For this reason, it is recommended that personality traits should be taken into consideration in designing the education systems and other variables that affect the acceptance and individual usage of the systems should be investigated. Although there is less impact of 2%, it can be said that each difference is important in terms of considering the effect of the system on designing the systems. The founded low impact could be explained with other variables. In the study of Siddiquei and Khalid (2018) it is reported that there is a relation between personality traits, learning styles and academic performance of e-learners. This finding is important to look for another variable in future studies to discuss and compare the obtained impact. 2. Considering in the context of the recent studies it is possible to claim that the added value of the present research for readers is a pedagogical point of view because of working within the framework of TAM and working in a non-profit organization (i.g university) through cloud computing systems applications in the developing and changing world. The results discussed below considering the literature.

### **THE DIRECT AND INDIRECT EFFECTS OF BIG 5 ON PEU, PU, AND BI IN ASSESSING THE USE OF CCSS IN EDUCATION**

In this study, the components Extroversion, Conscientiousness, Agreeableness, Nervousness, and Openness to Experiences account as given in BIG 5 were used. According to the results, among the individual differences only NEUR is the significant predictor of PEU variable. In the study of Saadé and Kira (2007) anxiety was shown to present some moderating influence on perceived ease of use (PEU), and they state trait anxiety is defined as a general pervasive anxiety that is experienced by a person over the entire range of life experience. Reed et al. (1996) states previous experience on computers is posited as a factor influencing the computer anxiety. Based on the studies it is possible to say nervousness person could have an anxiety while using computer technologies, and this could be a negative effect on perceived ease of use. Considering the sample characteristics, they might not have an experience on CCSS previously. Although this issue is the limitation of present study, it is important to note that having a previous experience on computers might play an important role on perceived ease of use. Venkatesh and Davis (2000) and Venkatesh and Bala (2008) emphasis the moderator role of experience on the acceptance and usage of a technology in the model of TAM 2 and TAM 3, respectively. The results are parallel with the literature considering the indirect effect of NEUR on BI (Punnoose, 2012). Additionally, it is also claimed that nervousness personality type could have possible additional effects on PEU (Punnoose, 2012). Contrary to the literature PU is directly and positively predicted by NEUR (Komarraju & Karau, 2005; Teh et al., 2011), and extroversion could have possible additional effects on PU, PEU and BI (Punnoose, 2012; Svendsen et al., 2009). Another results for conscientiousness were shown some differences compared to literature. While it has a positive direct effect on PU (Devaraj et al., 2008; Komarraju & Karau, 2005; Punnoose, 2012), this trait could have a possible additional effect on BI and has no relation with PEU (Punnoose, 2012). In addition to the contradictory, agreeableness has a significant positive direct effect on PU (Devaraj et al., 2008) and it is also suggested that agreeableness could have a possible additional effect BI (Punnoose, 2012). Finally, openness to experience has a significant positive direct effect on PU, (Komarraju & Karau, 2005), and on BI (Devaraj et al., 2008; Jacques et al., 2009). It is also stated that openness to experience is significantly and positively related to perceived ease of use (Svendsen et al., 2013) which is contradictory to the present studies result.

### **THE DIRECT AND INDIRECT EFFECTS OF PEU ON PU AND BI, AND PU ON BI ASSESSING THE USE OF CCSS IN EDUCATION**

The findings also show that BI is significantly predicted by PU and PEU variables. This finding can be supported with the studies in the literature (Padilla-Meléndez et al., 2013; Terzis & Economides, 2011). In the study, personality variable do not meaningfully predict PU and BI,

and it is considered that this finding is related with the characteristics of the sample from which the data were collected. Considering the fact that the participants do not have a job and the fact that they are enrolled in this program to find a job in the Ministry of Education. Considering the program structure within the context of education pedagogy, they all expect to be a teacher after completing this program. Moreover, this finding might be explained by the following reasons: The participants are not experienced in cloud technologies, they do not use them that much in their lives, and they are not closely acquainted with such systems. Besides believing in the necessity of using technology in accordance with the others' expectations is not related with personality traits. Moreover, the findings of the study demonstrate that there is not a significant relationship between these predicted independent and dependent variables. In contrast to the findings of Jackson et al. (2013) personal innovativeness (individual user characteristics, (Zmud & Apple, 1992) on Internet technologies had significant direct effect on BI. However, in this study the results of PU and personality trait contradicts the findings of Uffen et al. (2013) in which it is claimed that neuroticism is negatively correlated with the perceived usefulness and behavioural control. This may be due to the cultural differences of the subjects groups in the use of technologies. Furthermore, the unfamiliarity of the subjects to the use of cloud computing technologies may have given rise to our findings. On the other hand, although PU and personality traits are important factors on the university students' information systems acceptance behaviour (Li, 2016), the findings in this study is contradictory to that. This may have been affected by the attendance patterns of the students concerned (i.e. weekend attendance only). This diminishes their chances of observing the use of such technologies by others which impacts the students' perception of usefulness. It is also possible to draw similar conclusions for other dependent parameter PEU and BI with the exception of NEUR independent variable.

The results show that openness to experience and extroversion were not significantly correlated with any components. However, only nervousness has a significant effect of PEU. Neurotics have trouble in performing a work since they have negative feelings. Therefore, the participants having high score in those traits are more likely to be affected by PEU in the use of CCSs. Xua et al. (2016) noted that less extrovert persons are more likely to adopt mobile gaming apps. Furthermore, nervousness is negatively correlated with PEU. PEU and the above-mentioned individual differences are highlighted and consistent in Rosen and Kluemper's study (2008), where the impact of personality types on the acceptance of social networking is presented.

Finally, this study suggests that considering individual differences while adapting a new technology into the classroom might affect the efficient and sufficient usage of technologies and outlines future research opportunities. Thus, it seems vital for researchers in the future to consider the individual and also cultural differences on the acceptance and individual usage. These results can be used to improve the technology acceptance models in integrating new technologies into the future classrooms. Furthermore, it is suggested that it is important to see the direct and indirect effects of different personality traits -not only the main components of behavioural intention- on the whole components of TAM3. Also, focusing on the academic performance of teachers according to their personality by using TAM3 can be useful to shed a light on future studies.

## LIMITATIONS OF THE STUDY AND SUGGESTIONS FOR FURTHER STUDIES

The findings might stem from the characteristics of the sample- attending a certificate program which could be taken in account of a life-long program. CCSs could be more useful for the participants that have been already working in a job, and this is the limitation of the study by not having any data whether they have an occupation or not. Future studies could investigate the participants if they are working. Furthermore, the lack of awareness and experience of the participants on CCSs could be another reason on results. The fact that it predicts at a very low level is thought to be related with this. Besides, it can be seen that the characteristic of the sample in this study is efficient in TAM acceptance. When the fact that the sample should have similar characteristics is considered in the future studies, creating experience and making them believe that it is related to the job are thought to have an effect on acceptancy, and they can increase this. Further studies can also be conducted with individuals who have advanced command of technology, and it might yield different results.

The authors have no competing interests to declare.

## AUTHOR AFFILIATIONS

**Hursit Cem Salar**  [orcid.org/0000-0003-3986-0342](https://orcid.org/0000-0003-3986-0342)

Pamukkale University, Turkey

**Nazire Burcin Hamutoglu**  [orcid.org/0000-0003-0941-9070](https://orcid.org/0000-0003-0941-9070)

Eskisehir Technical University, Turkey

## REFERENCES

- Agarwal, R., & Prasad, J.** (1999). Are individual differences germane to the acceptance of new information technologies? *Decision sciences*, 30(2), 361–391. DOI: <https://doi.org/10.1111/j.1540-5915.1999.tb01614.x>
- Aksay, K.** (2015). Örgüt Yapılarında Yaşanan Değişimler ve Modern Örgüt Tiplerinin İncelenmesi. *Kent Akademisi*, 8(23), 111–128. <https://dergipark.org.tr/tr/pub/kent/issue/34397/379892>
- Alajlan, N., Hadwan, M., & Ibrahim, D. M.** (2022). Effectiveness of Adopting Cloud-Based E-Learning at Qassim University. *The Computer Journal*, 65(5), 1098–1106. DOI: <https://doi.org/10.1093/comjnl/bxaa146>
- Allport, G. W.** (1961). *Pattern and Growth in Personality*. New York: Holt, Rinehart & Winston. <https://psycnet.apa.org/record/1962-04728-000>
- Anshari, M., bin Alas, Y., & Guan, L. S.** (2015). Pervasive knowledge, social networks, and cloud computing: e-learning 2.0. *EURASIA Journal of Mathematics, Science and Technology Education*, 11(5), 909–921. DOI: <https://doi.org/10.12973/eurasia.2015.1360a>
- Arts, J. W. C., Frambach, R. T., & Bijmolt, T. H. A.** (2011). Generalizations on consumer innovation adoption: a meta-analysis on drivers of intention and behaviour. *International Journal of Research in Marketing*, 28 (2), 134–144. DOI: <https://doi.org/10.1016/j.ijresmar.2010.11.002>
- Bai, S., Hao, B., Li, A., Yuan, S., Gao, R., & Zhu, T.** (2013). Predicting Big Five Personality Traits of Microblog Users. *IEEE/WIC/ACM International Conferences on Web Intelligence (WI) and Intelligent Agent Technology (IAT)*. DOI: <https://doi.org/10.1109/WI-IAT.2013.70>
- Barnett, T., Pearson, W. A., Pearson, R., & Kellermanns, F. W.** (2015). Five-factor model personality traits as predictors of perceived and actual usage of technology. *European Journal of Information Systems*, 24(4), 374–390. DOI: <https://doi.org/10.1057/ejis.2014.10>
- Barrick, M. R., & Mount, M. K.** (2000). Select on conscientiousness and emotional stability. In E. A. Locke (Ed.), *Handbook of Principles of Organizational Behavior*. Blackwell Publishing.
- Baumgartner, H., & Homburg, C.** (1996). Applications of structural equation modeling in marketing and consumer research: A review. *International Journal of Research in Marketing*, 13(2), 139–161. DOI: [https://doi.org/10.1016/0167-8116\(95\)00038-0](https://doi.org/10.1016/0167-8116(95)00038-0)
- Bentler, P. M., & Bonett, D. G.** (1980). Significance tests and goodness of fit in the analysis of covariance structures. *Psychological Bulletin*, 88, 588–606. DOI: <https://doi.org/10.1037/0033-2909.88.3.588>
- Bollen, K. A.** (1990). Political Democracy: Conceptual and measurement traps. *Studies in comparative international development*, 25(1), 7–24. DOI: <https://doi.org/10.1007/BF02716903>
- Browne, M. W., & Cudeck, R.** (1993). Alternative ways of assessing model fit. In K. A. Bollen & J. S. Long (Eds.), *Testing structural equation models* (pp. 136–162). Sage.
- Byrne, B. M.** (2001). Structural equation modeling with AMOS, EQS, and LISREL: Comparative approaches to testing for the factorial validity of a measuring instrument. *International Journal of Testing*, 1(1), 55–86. DOI: [https://doi.org/10.1207/S15327574IJT0101\\_4](https://doi.org/10.1207/S15327574IJT0101_4)
- Correa, T., Hinsley, A., & Ziga, H.** (2010). Who interacts on the web? The intersection of users' personality and social media use. *Computers in Human Behaviour*, 26(2), 247–253. DOI: <https://doi.org/10.1016/j.chb.2009.09.003>
- Costa, P., & McCrae, R.** (1992). Four ways five factors are basic. *Personality and Individual Differences*, 13(6), 653–665. DOI: [https://doi.org/10.1016/0191-8869\(92\)90236-I](https://doi.org/10.1016/0191-8869(92)90236-I)
- Costa, P. T., McCrae, R. R., & Dye, D. A.** (1991). Facet Scales for Agreeableness and Conscientiousness: A Revision of the NEO Personality Inventory. *Personality and Individual Differences*, 12(9), 887–898. DOI: [https://doi.org/10.1016/0191-8869\(91\)90177-D](https://doi.org/10.1016/0191-8869(91)90177-D)
- Davis, F. D.** (1989). Perceived usefulness, perceived ease of use, and user acceptance of information technology. *MIS Quarterly*, 13(3), 319–340. DOI: <https://doi.org/10.2307/249008>
- Devaraj, S., Easley, R. F., & Crant, J. M.** (2008). How does personality matter? Relating the five-factor model to technology acceptance and use. *Information System Research*, 19(1), 93–105. DOI: <https://doi.org/10.1287/isre.1070.0153>

- DeYoung, C. G., Peterson, J. B., & Higgins, D. M.** (2005). Sources of openness/intellect: Cognitive and neuropsychological correlates of the fifth factor of personality. *Journal of personality*, 73(4), 825–858. DOI: <https://doi.org/10.1111/j.1467-6494.2005.00330.x>
- Digman, J. M.** (1990). Personality structure: Emergence of the five-factor model. *Annual Review of Psychology*, 41, 417–440. DOI: <https://doi.org/10.1146/annurev.ps.41.020190.002221>
- Dwivedi, Y., Williams, M., Ramdani, B., Niranjan, S., & Weerakkody, V.** (2011). Understanding factors for successful adoption of Web 2.0 applications. *Proceedings of the 19th European Conference on Information Systems*. <https://aisel.aisnet.org/cgi/viewcontent.cgi?article=1262&context=ecis2011>
- Eysenck, H. J.** (1991). Dimensions of personality: 16, 5 or 3?—Criteria for a taxonomic paradigm. *Personality and individual differences*, 12(8), 773–790. DOI: [https://doi.org/10.1016/0191-8869\(91\)90144-Z](https://doi.org/10.1016/0191-8869(91)90144-Z)
- Garcia-Penalvo, F. J., Johnson, M., Alves, G. R., Minovic, M., & Conde-Gonzales, M. A.** (2014). Informal learning recognition through a cloud ecosystem. *Future Generation Computer Systems*, 32, 282–294. DOI: <https://doi.org/10.1016/j.future.2013.08.004>
- Goldberg, L. R.** (1992). The development of the markers for the big-five factor structure. *Psychological Assessment*, 4(1), 26–42. <https://psycnet.org/buy/1992-25730-001>. DOI: <https://doi.org/10.1037/1040-3590.4.1.26>
- Google Apps for Education.** (2015). [https://edu.google.com/intl/tr/?modal\\_active=none](https://edu.google.com/intl/tr/?modal_active=none)
- Gosling, S. D., Rentfrow, P. J., & Swann, W. B.** (2003). A very brief measure of the Big-Five personality domains. *Journal of Research in Personality*, 37, 504–528. DOI: [https://doi.org/10.1016/S0092-6566\(03\)00046-1](https://doi.org/10.1016/S0092-6566(03)00046-1)
- Gunel, O. D.** (2010). Isletmelerde yıldırma olgusu ve yıldırma mağdurlarının kişilik özelliklerine ilişkin bir araştırma [Mobbing in organizations and a research on mobbing victims' personality characteristics]. *Dokuz Eylül Üniversitesi Sosyal Bilimler Enstitüsü Dergisi* [Dokuz Eylül University Social Science Institute Journal], 12, 37–65. <https://acikerisim.deu.edu.tr/xmlui/handle/20.500.12397/5646>
- Hamutoglu, N. B.** (2018). Bulut bilişim teknolojileri kabul modeli 3: ölçek uyarlama çalışması. *Sakarya University Journal of Education*, 8(2), 8–25. DOI: <https://doi.org/10.19126/suje.297586>
- Heller, D., Judge, T., & Watson, D.** (2002). The confounding role of personality and trait affectivity in the relationship between job and life satisfaction. *Journal of Organizational Behaviour*, 23(7), 815–835. DOI: <https://doi.org/10.1002/job.168>
- Hermans, R., Tondeur, J., van Braak, J., & Valcke, M.** (2008). The impact of primary school teachers' educational beliefs on the classroom use of computers. *Computers & Education*, 51(4), 1499–1509. DOI: <https://doi.org/10.1016/j.compedu.2008.02.001>
- Hu, L., & Bentler, P. M.** (1999). Cutoff criteria for fit indexes in covariance structure analysis: Conventional criteria versus new alternatives. *Structural Equation Modeling*, 6(1), 1–55. DOI: <https://doi.org/10.1080/10705519909540118>
- Huang, Y. M., Chen, H. C., Hwang, J. P., & Huang, Y. M.** (2013). Application of cloud technology, social networking sites and sensing technology to e-learning. In *Reshaping learning* (pp. 343–364). Springer. DOI: [https://doi.org/10.1007/978-3-642-32301-0\\_15](https://doi.org/10.1007/978-3-642-32301-0_15)
- Jackson, J. D., Mun, Y. Y., & Park, J. S.** (2013). An empirical test of three mediation models for the relationship between personal innovativeness and user acceptance of technology. *Information & Management*, 50(4), 154–161. DOI: <https://doi.org/10.1016/j.im.2013.02.006>
- Jacques, P. H., Garger, J., Brown, C. A., & Deale, C. S.** (2009). Personality and virtual reality team candidates: The roles of personality traits, technology anxiety and trust as predictors of perceptions of virtual reality teams. *Journal of Business and Management*, 15(2), 143. [https://www.chapman.edu/business/\\_files/journals-and-essays/jbm-editions/jbm-vol-15-02.pdf#page=39](https://www.chapman.edu/business/_files/journals-and-essays/jbm-editions/jbm-vol-15-02.pdf#page=39)
- Jeong, H. I., & Kim, Y.** (2016). The acceptance of computer technology by teachers in early childhood education. *Interactive Learning Environments*, 25(4), 496–512. DOI: <https://doi.org/10.1080/10494820.2016.1143376>
- Joreskog, K. G., & Sorbom, D.** (1993). *Lisrel 8: Structural Equation Modeling with the SIMPLIS Command Language*. Lincolnwood, IL: Scientific International Software, Inc.
- Kalogiannakis, M.** (2010). Training with ICT for ICT from the trainee's perspective. A local ICT teacher training experience. *Education and Information Technologies*, 15(1), 3–17. <https://link.springer.com/article/10.1007/s10639-008-9079-3>. DOI: <https://doi.org/10.1007/s10639-008-9079-3>
- Kamyab, M., & Delafrooz, N.** (2016). Investigating the Effect of Personality Traits, Subjective Norms and Perceptions of Customers on using Internet Banking. *Indian Journal of Science and Technology*, 9(1), 1–8. DOI: <https://doi.org/10.17485/ijst/2016/v9i1/73400>
- Kaufman, J. C., Agars, M. D., & Lopez-Wagner, M. C.** (2008). The role of personality and motivation in predicting early college academic success in non-traditional students at a Hispanic-serving institution. *Learning and Individual Differences*, 18, 492–496. DOI: <https://doi.org/10.1016/j.lindif.2007.11.004>
- Kelly, M., & James, C. M.** (2012). The influence of personality on Facebook usage, wall postings and regret. *Computers in Human Behaviour*, 28, 267–274. DOI: <https://doi.org/10.1016/j.chb.2011.09.009>
- Klein, J. T.** (2010). A taxonomy of interdisciplinarity. *The Oxford handbook of interdisciplinarity*, 15, 15–30.

- Kline, R. B. (2011). *Principles and practice of structural equation modeling*. The Guilford Press.
- Komarraju, M., & Karau, S. J. (2005). The relationship between the big five personality traits and academic motivation. *Personality and Individual Differences*, 39, 557–567. DOI: <https://doi.org/10.1016/j.paid.2005.02.013>
- Kuba, J. (2014). Konstruktová validita Bochumského osobnostního dotazníku: *Motivační dimenze*. *Testforum*, 4, 74–83. DOI: <https://doi.org/10.5817/TF2014-4-19>
- Li, C. Y. (2016). Understanding University Students' System Acceptance Behavior: The Roles of Personality Trait and Subjective Norms. *International Journal of Technology and Human Interaction (IJTHI)*, 12(3), 106–125. DOI: <https://doi.org/10.4018/IJTHI.2016070107>
- Lu, Y., Papagiannidis, S., & Alamanos, E. (2019). Exploring the emotional antecedents and outcomes of technology acceptance. *Computers in Human Behavior*, 90, 153–169. DOI: <https://doi.org/10.1016/j.chb.2018.08.056>
- Maican, C. I., Cazan, A. M., Lixandriou, R. C., & Dovleac, L. (2019). A study on academic staff personality and technology acceptance: The case of communication and collaboration applications. *Computers & Education*, 128, 113–131. DOI: <https://doi.org/10.1016/j.compedu.2018.09.010>
- Marino, C., Vieno, A., Lenzi, M., Fernie, B. A., Nikčević, A. V., & Spada, M. M. (2018). Personality traits and metacognitions as predictors of positive mental health in college students. *Journal of Happiness Studies: An Interdisciplinary Forum on Subjective Well-Being*, 19(2), 365–379. DOI: <https://doi.org/10.1007/s10902-016-9825-y>
- Marsh, H. W., Hau, K. T., Artelt, C., Baumert, J., & Peschar, J. L. (2006). OECD's brief self-report measure of educational psychology's most useful affective constructs: Cross-cultural, psychometric comparisons across 25 countries. *International Journal of Testing*, 6(4), 311–360. DOI: [https://doi.org/10.1207/s15327574ijt0604\\_1](https://doi.org/10.1207/s15327574ijt0604_1)
- McCrae, R. R., & John, O. P. (1992). An introduction to the five-factor model and its applications. *Journal of Personality*, 60, 175–215. DOI: <https://doi.org/10.1111/j.1467-6494.1992.tb00970.x>
- McCrae, R. R., & Costa, P. T., Jr. (1997). Personality trait structure as a human universal. *American Psychologist*, 52(5), 509–516. DOI: <https://doi.org/10.1037/0003-066X.52.5.509>
- Moore, G. C., & Benbasat, I. (1991). Development of an instrument to measure the perceptions of adopting an information technology innovation. *Information Systems Research*, 2(3), 192–222. DOI: <https://doi.org/10.1287/isre.2.3.192>
- Nistor, N., Gögüş, A., & Lerche, T. (2013). Educational technology acceptance across national and professional cultures: a European study. *Educational Technology Research and Development*, 61(4), 733–749. <https://link.springer.com/article/10.1007/s11423-013-9292-7>. DOI: <https://doi.org/10.1007/s11423-013-9292-7>
- Özbek, V., Alnıaçık, Ü., Koc, F., Akkılıç, M. E., & Kaş, E. (2014). The impact of personality on technology acceptance: A study on smart phone users. *Procedia-Social and Behavioral Sciences*, 150, 541–551. DOI: <https://doi.org/10.1016/j.sbspro.2014.09.073>
- Padilla-Meléndez, A., Del Aguila-Obra, A. R., & Garrido-Moreno, A. (2013). Perceived playfulness, gender differences and technology acceptance model in a blended learning scenario. *Computers & Education*, 63, 306–317. DOI: <https://doi.org/10.1016/j.compedu.2012.12.014>
- Pearson, M., & Naylor, S. (2006). Changing contexts: teacher professional development and ICT pedagogy. *Education and Information Technologies*, 11(3–4), 283–291. <https://link.springer.com/article/10.1007/s10639-006-9013-5>. DOI: <https://doi.org/10.1007/s10639-006-9013-5>
- Prestridge, S. (2010). The alignment of digital pedagogy to current teacher beliefs. *Paper presented at ACEC2010: Digital Diversity*. Melbourne, Australia: Australian Council for Computers in Education. <https://core.ac.uk/download/pdf/143862718.pdf>
- Punnoose, A. C. (2012). Determinants of Intention to Use eLearning Based on the Technology Acceptance Model. *Journal of Information Technology Education*, 11, 302–337. <https://www.learntechlib.org/p/111507>. DOI: <https://doi.org/10.28945/1744>
- Reed, W. M., Ayersman, D. J., & Liu, M. (1996). The effect of students' computer-based prior experiences and instructional exposures on the application of hypermedia-related mental models. *Journal of Educational Computing Research*, 14(2), 175–197. DOI: <https://doi.org/10.2190/TVP7-KDD3-MHKP-6AHW>
- Rivers, D. J. (2021). The role of personality traits and online academic self-efficacy in acceptance, actual use and achievement in Moodle. *Education and Information Technologies*, 26(4), 4353–4378. DOI: <https://doi.org/10.1007/s10639-021-10478-3>
- Rogers, E. (1995). *Diffusion of innovations*. New York: Free Press.
- Rosen, P. A., & Kluemper, D. H. (2008). The Impact of the Big Five Personality Traits on the Acceptance of Social Networking Website. *AMCIS Proceedings*, 274. <https://aisel.aisnet.org/cgi/viewcontent.cgi?article=1276&context=amcis2008>
- Saadé, R. G., Kira, D., Nebebe, F., & Otrakji, C. (2006). Openness to Experience: An HCI Experiment. *Issues in informing science & information technology*, 3. <http://citeseerx.ist.psu.edu/viewdoc/download?doi=10.1.1.381.7465&rep=rep1&type=pdf>. DOI: <https://doi.org/10.28945/2944>

- Saadé, R. G., & Kira, D.** (2007). Mediating the impact of technology usage on perceived ease of use by anxiety. *Computers & education*, 49(4), 1189–1204. DOI: <https://doi.org/10.1016/j.compedu.2006.01.009>
- Sanders, A.** (2008). Using personality traits to predict police officer performance Policing. *An International Journal of Police Strategies & Management*, 31(1), 129–147. DOI: <https://doi.org/10.1108/13639510810852611>
- Schermelleh-Engel, K., & Moosbrugger, H.** (2003). Evaluating the fit of structural equation models: Tests of significance and descriptive goodness-of-fit measures. *Methods of Psychological Research Online*, 8(2), 23–74. <http://citeseerx.ist.psu.edu/viewdoc/download?doi=10.1.1.509.4258&rep=rep1&type=pdf>
- Siddiquei, N. L., & Khalid, R.** (2018). The relationship between Personality Traits, Learning Styles and Academic Performance of E-Learners. *Open Praxis*, 10(3), 249–263. DOI: <https://doi.org/10.5944/openpraxis.10.3.870>
- Srite, M., & Karahanna, E.** (2006). The role of espoused national cultural values in technology acceptance. *MIS quarterly*, 679–704. DOI: <https://doi.org/10.2307/25148745>
- Steiger, J. H.** (2007). Understanding the limitations of global fit assessment in structural equation modeling. *Personality and Individual Differences*, 42(5), 893–98. DOI: <https://doi.org/10.1016/j.paid.2006.09.017>
- Svendsen, B. G., Johnsen, K. J., Almås-Sørensen, L., & Vittersø, J.** (2013). Personality and technology acceptance: the influence of personality factors on the core constructs of the Technology Acceptance Model. *Behaviour & Information Technology*, 32(4), 323–334. DOI: <https://doi.org/10.1080/0144929X.2011.553740>
- Tanaka, J. S., & Huba, G. J.** (1985). A fit index for covariance structure models under arbitrary GLS estimation. *British Journal of Mathematical and Statistical Psychology*, 38, 197–201. DOI: <https://doi.org/10.1111/j.2044-8317.1985.tb00834.x>
- Teh, P.-L., Yong, C.-C., Chong, C.-W., & Yew, S.-Y.** (2011). Do the big five personality factors affect knowledge sharing behaviour? A study of Malaysian universities. *Malaysian Journal of Library & Information Science*, 16(1), 47–62. <https://mjlis.um.edu.my/article/view/6682>
- Terzis, V., & Economides, A. A.** (2011). Computer based assessment: Gender differences in perceptions and acceptance. *Computers in Human Behavior*, 27(6), 2108–2122. DOI: <https://doi.org/10.1016/j.chb.2011.06.005>
- Thoms, P. Moore, K. S., & Scott, K. S.** (1996). The relationship between self-efficacy for participating in self-managed work groups and the big five personality dimensions: Summary. *Journal of Organizational Behavior*, 17(4), 349–362. DOI: [https://doi.org/10.1002/\(SICI\)1099-1379\(199607\)17:4<349::AID-JOB756>3.0.CO;2-3](https://doi.org/10.1002/(SICI)1099-1379(199607)17:4<349::AID-JOB756>3.0.CO;2-3)
- Tsai, C. C., & Chai, C. S.** (2012). The “third”-order barrier for technology-integration instruction: Implications for teacher education. Building the ICT capacity of the next generation of teachers in Asia. *Australasian Journal of Educational Technology*, 28, 1057–1060. DOI: <https://doi.org/10.14742/ajet.810>
- Uffen, J., Kaemmerer, N., & Breitner, M. H.** (2013). Personality traits and cognitive determinants — an empirical investigation of the use of smartphone security measures. *Journal of Information Security*, 10, 203–212. DOI: <https://doi.org/10.4236/jis.2013.44023>
- Utami, I. Q., Fahmihay, I., Ningrum, R. A., Fakhruzzaman, M. N., Pratama, A. I., & Triangga, Y. M.** (2022). Teacher’s acceptance toward cloud-based learning technology in Covid-19 pandemic era. *Journal of Computers in Education*, 9, 571–586. DOI: <https://doi.org/10.1007/s40692-021-00214-8>
- Venkatesh, V., & Bala, H.** (2008). Technology Acceptance Model 3 and research Agenda on Interventions. *Decision Sciences*, 39(2), 273–315. DOI: <https://doi.org/10.1111/j.1540-5915.2008.00192.x>
- Venkatesh, V., & Davis, F. D.** (2000). A Theoretical Extension of the Technology Acceptance Model: Four Longitudinal Field Studies. *Management Science*, 46(2), 186–204. DOI: <https://doi.org/10.1287/mnsc.46.2.186.11926>
- Venkatesh, V., & Susan, A. B.** (2001). A Longitudinal investigation of personal computers in homes – adoption determinants and emerging challenges. *MIS Quarterly*, 25(1), 71–102. DOI: <https://doi.org/10.2307/3250959>
- Venkatesh, V., Morris, M. G., Davis, G. B., & Davis, F. D.** (2003). User acceptance of information technology: Toward a unified view. *MIS Quarterly*, 27, 425–478. DOI: <https://doi.org/10.2307/30036540>
- Wang, H. I., & Yang, H. L.** (2005). The role of personality traits in UTAUT model under online stocking. *Contemporary Management Research*, 1(1), 69–82. DOI: <https://doi.org/10.7903/cmr.73>
- Windschitl, M.** (2002). Framing constructivism in practice as the negotiation of dilemmas: An analysis of the conceptual, pedagogical, cultural, and political challenges facing teachers. *Review of Educational Research*, 72(2), 131–175. DOI: <https://doi.org/10.3102/00346543072002131>

- Xua, R., Freya, R. M., Fleischa, E., & Ilicb, A.** (2016). Understanding the impact of personality traits on mobile app adoption – Insights from a large-scale field study. *Computers in Human Behaviour*, 62, 244–256. DOI: <https://doi.org/10.1016/j.chb.2016.04.011>
- Zmud, R. W., & Apple, R. E.** (1992). Measuring Technology Incorporation/Infusion. *Journal of product Innovation Management*, 9, 148–155. DOI: [https://doi.org/10.1016/0737-6782\(92\)90006-X](https://doi.org/10.1016/0737-6782(92)90006-X)

**TO CITE THIS ARTICLE:**

Salar, H. C., & Hamutoglu, N. B. (2022). The Role of Perceived Ease of Use and Perceived Usefulness on Personality Traits among Adults. *Open Praxis*, 14(2), pp. 133–147. DOI: <https://doi.org/10.55982/openpraxis.14.2.142>

**Submitted:** 14 September 2021

**Accepted:** 13 March 2022

**Published:** 09 December 2022

**COPYRIGHT:**

© 2022 The Author(s). This is an open-access article distributed under the terms of the Creative Commons Attribution 4.0 International License (CC-BY 4.0), which permits unrestricted use, distribution, and reproduction in any medium, provided the original author and source are credited. See <http://creativecommons.org/licenses/by/4.0/>.

*Open Praxis* is a peer-reviewed open access journal published by International Council for Open and Distance Education.